



USER MANUAL FOR KNIDOS

USER MANUAL FOR KNIDOS

1.	Foreword	3
2.	Introduction	3
3.	Warning And Definition Stickers On The Case	5
4.	Norms And Certificates	6
5.	Installation And Environmental Situations	6
6.	Care And Cleaning	7
7.	Electricity Connection	8
8.	Recycle Parts	8
9.	Loading Goods	9
10.	Technical Details	10
11.	Installation and Assembly	25

1. Foreword

Dear Customer,

Please be sure to read this operating manual carefully before putting your new device into use. The manual contains important notes on safety and proper installation, use and maintenance of the device.

Please keep the manual ready for reference and hand it over to any future new owner of the device. Make sure the manual is read by all staff who may use or work with the cabinets and that they understand and observe the contents.

To ensure safe operation in all service conditions, the following safety precautions must be observed:

- Contact your Service Organization if you are in any doubt about electrical connection, working or safety of your refrigerated cabinets.
- Never detach any cover except where specifically instructed in this manual. Doing so might expose live electrical parts.
- Never use a water hose or high-pressure jet to clean the device.
- All work on electrical equipment must be left to a qualified electrician.
- Please pay attention to the maximum load limits when filling the display shelves.
- Electrical elements may only be replaced by a qualified electrician or person with experience in electrical engineering!
- Wear safety gloves when cleaning and servicing the device.

Ahmet Yar cabinets does not contain PCB, PCT, asbestos, formaldehyde, cadmium or substances which interfere with moistening.

Producer company does not have any responsibilities about the situations below:

Wrong usage of the refrigerator, Wrong assembling, Electrical Effects, Not doing the periodical cares, Changes of operation, Not using the original spare parts, Ignoring the given infos.

(Some of the explanations and applications may vary depending on the device type and model.)

2. Introduction

This guide is prepared for the KNIDOS cabinet. The details below are examined in general; How the refrigerator will be used, technical details, installation and assembling infos and suggestions for the users-care operations.

KNIDOS is a pool type freezer which preserves frozen foods. It is suitable for use in markets and hypermarkets with its high performance, wide display and loading capacity. It has been designed in a way to easily meet all expectations of the customers with its modern design and functional details, double-sided cabinet application, optionally cooling at different degrees in both directions, and the possibility of choosing colors suitable for the decor

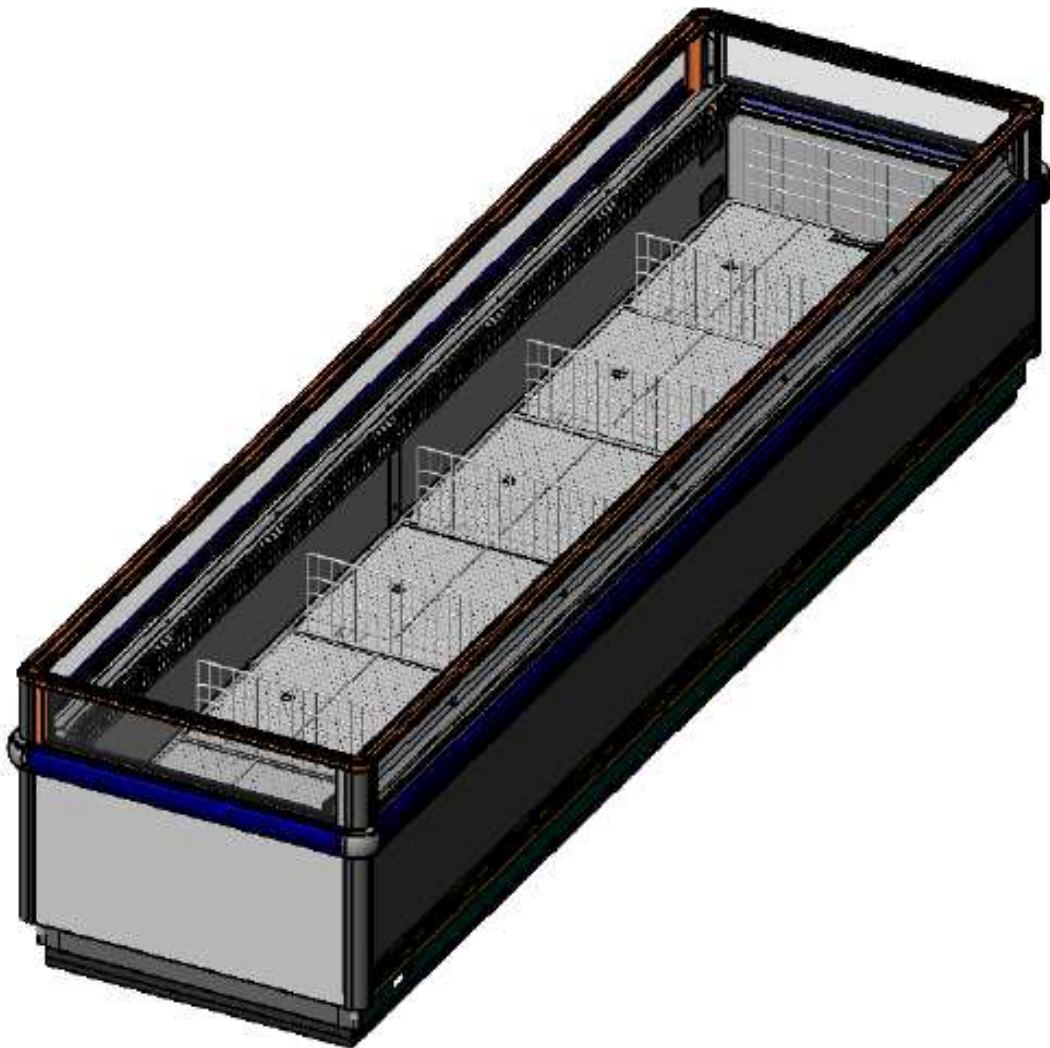

3. Warning and definition stickers on the case

- Product Definition Sticker (Fig.1): Product definition sticker is located inside the cabinet on the ceiling and it can include all technical properties as below: Logo and address info of the producer company, product certificates and quality certificates of the producer, model of the product, article no, serial number of the product, production date of the product, air conditioner class of the product, temperature range of the cabinet, type of refrigerant, test pressure, working pressure, working voltage info, approved certificates of the product and the standards & directives, fans supply voltage info, power of evaporator fans, power of led lights, power of drain heaters, power of defrost heaters, power of glass heaters, load max.. etc.
- High Voltage Sticker (Fig.2): High voltage sticker is located on the electricity box.
- Loading Sticker (Fig.3): There are palettes located on the refrigerator for transportation. Transportations with forklifts or transpalettes are materialized by the assistance of these palettes. There is a sticker behind the refrigerator about the transportation palettes.
- Fragile Sticker (Fig.4): There are on the risk of fracture surfaces. Carefully moving is important and do not hit to hard materials. There are fragile stickers on the side walls.
- Foot Print Sticker (Fig.5): This sticker located on the base trays.
- Pressure Sticker (Fig.6): Pressure sticker is located at the exit points of the copper pipes. It is used for determining the quantity of nitrogen.

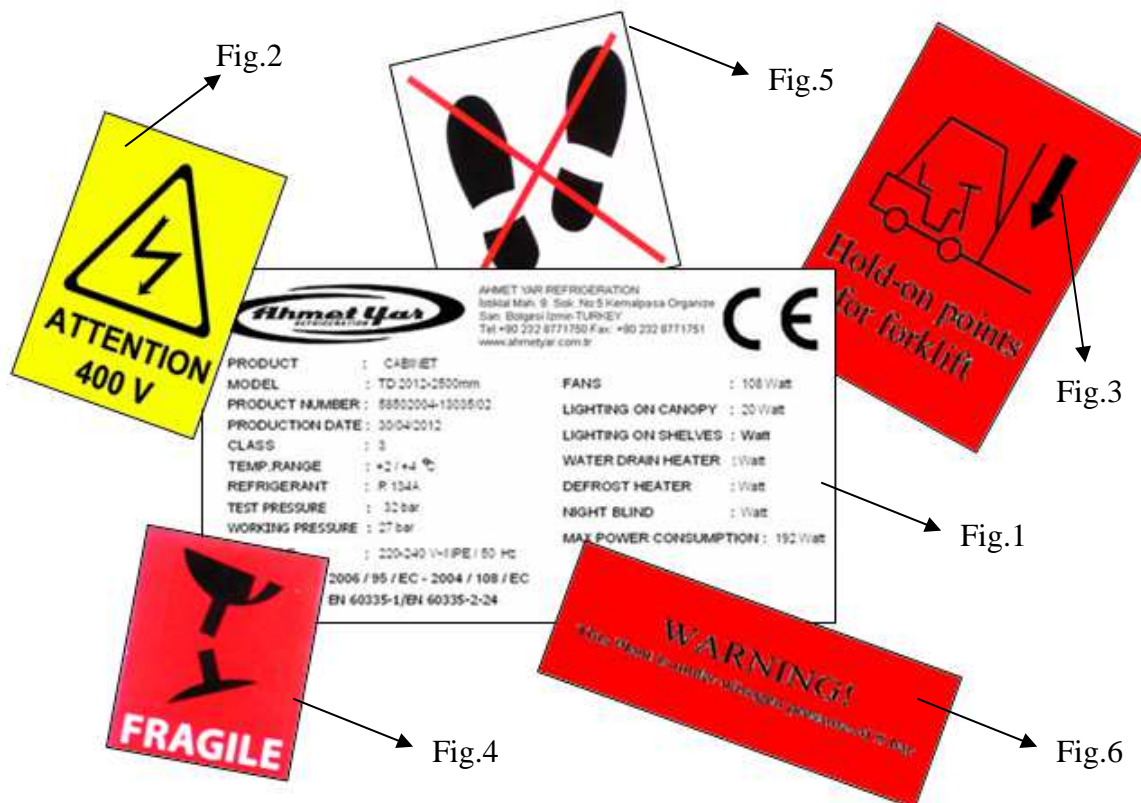

4. Norms and Certificates

The approved certificates of norms and refrigerators that are using as reference; EN 60204-1; EN 60439-1; EN 60439-2

ENVIRONMENTAL CLIMATIC ATMOSPHERE (EN 441-4)

This refrigerator is tested as to atmosphere heat class 3.

Class	Dry Air Temperature	Relative Humidity	Dew Point
1	16°C	%80	12°C
2	22°C	%65	15°C
3	25°C	%60	17°C
4	30°C	%55	20°C
5	40°C	%40	24°C
6	27°C	%70	21°C

The directives that the refrigerator suits EEC 73/23 , EEC 98/37

5. Installation and Environmental Situations

Follow the instructions below for installation.

The situations that must be paid attention to placing the cabinets. Do not leave or assemble the refrigerator at the positions below ;

- Do not place the cabinet under direct sunlight
- Do not place the cabinet in front of a door
- Do not place the cabinet near a heat sources
- Do not place the cabinet in front of direct air flow from an air condition or a vantilator.
- Do not place the cabinet outdoors

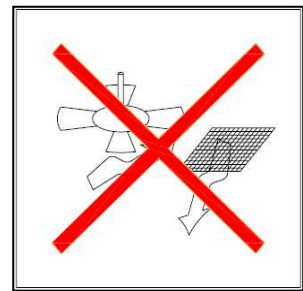
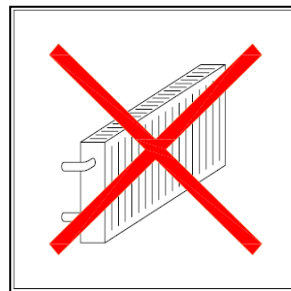
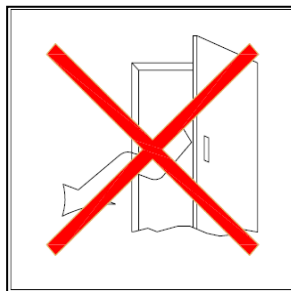
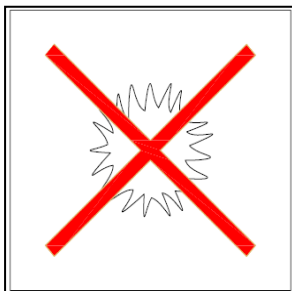

6. Care and Cleaning

Long life and satisfactory performance of any equipment is dependent upon the care it receives. To ensure long life, proper sanitation and minimum maintenance costs, these display Cases should thoroughly cleaned, all debris removed and the interiors washed down, weekly.



Fan Plenum

To facilitate cleaning, the fan plenum is hinged and also fastened with screws at each end. After cleaning be sure the plenum is properly lowered into position and that screws are reinstalled or product loss will result due to improper refrigeration.

Exterior Surfaces

The exterior surfaces should clean with a mild detergent and warm water to protect and maintain their attractive finish. Never use abrasive cleaners or scouring pads.

Interior Surfaces

The interior surfaces may cleaned with most domestic detergents, ammonia based cleaners and sanitizing solutions with no harm to the surface.

DO NOT USE:

Abrasive cleansers and scouring pads, as these will mar the finish. Solvent, oil or acidic based cleaners on any interior surfaces.

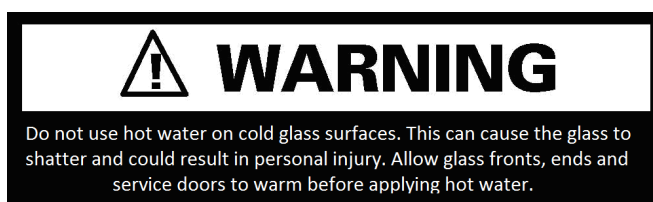

DO:

Remove the product and all loose debris to avoid clogging the waste outlet. Store product is in a refrigerated area such as a freezer. Remove only as much product as can be taken to the freezer in a timely manner.

First turn off refrigeration, and then disconnect electrical power.

Thoroughly clean all surfaces with soap and hot water. Do not use steam or high water pressure hoses to wash the interior. This will destroy the display cases sealing causing leaks and poor performance.

Remove screws and lift fan plenum for cleaning. Be sure to reposition the fan plenum after cleaning display cases.

Take care to minimize direct contact between fan motors and cleaning or rinse water. Rinse with hot water, but do not flood. Never introduce water faster than the waste outlet can remove it.

Allow display cases to dry before resuming operation.

After cleaning completed, turn on power and refrigerant to the Display Case. Verify that display case is working properly.

7. Electricity Connection

Details below must be examined while making the electrical connections.



- Protective automatic key and main power switch must be used against electric current on the device. Users must know where the key is kept in case of an emergency.
- Electric systems must be grounded.
- Maximum voltage difference must be guaranteed at %±6.
- The thickness of the cable on the energy line must be at least 2,5 mm² and must put up with high current.
- The cable of energy line must not be longer than 4-5m, depends on the conditions if cable length increases the cable cross-section must be increased too.
- For making the device works regularly, be sure you obtained the heat and the damp values which are regarded at EN441 and be sure the climate class is 3. (+25°C;R.H. 60%)
- The personnel who will interfere to the device must have electricity certificate.

8. Recycle Parts

All countries are disposing of waste according to EU laws and norms. Current Recycle Parts on the case;

Painted Metals: Pillars, shelves, legs, back panel, base tray, ceiling.

Copper-Aluminium: Condanser, evaporator and electrical parts.

Galvanised Steels: Bottom panels, painted panels, basic parts, base tray.

Polyurethane: Thermal injection.

Thermopane: Glass parts.

PVC: Handrails.

Polystyrene: Thermoform side endwalls.

Polycarbon: Lighting cover.

9. Loading Goods

Cabinet loading important rules that should be followed.

- Locate the goods to the shelves tidy.
- The overall load does not exceed the capacity of the shelves (160 kg/ m²).
- Shelves can be adjusted at different angles according to the device type (0°, 10°, 20°).
- To install packages in the closet, set max and do not leave blank space.
- Between the top shelf loaded with goods leave the 30mm gap.
- Ensure consumption of the substance and accordingly load.
- Except for the closet shelf and the base tray, do not install any goods.
- Do not obstruct the flow of refrigerated air.

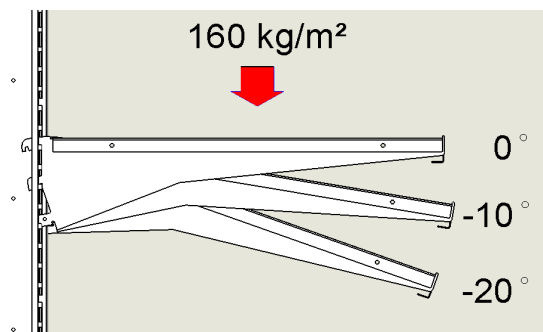

10. Technical Details



TECHNICAL DATA SHEET - KNIDOS

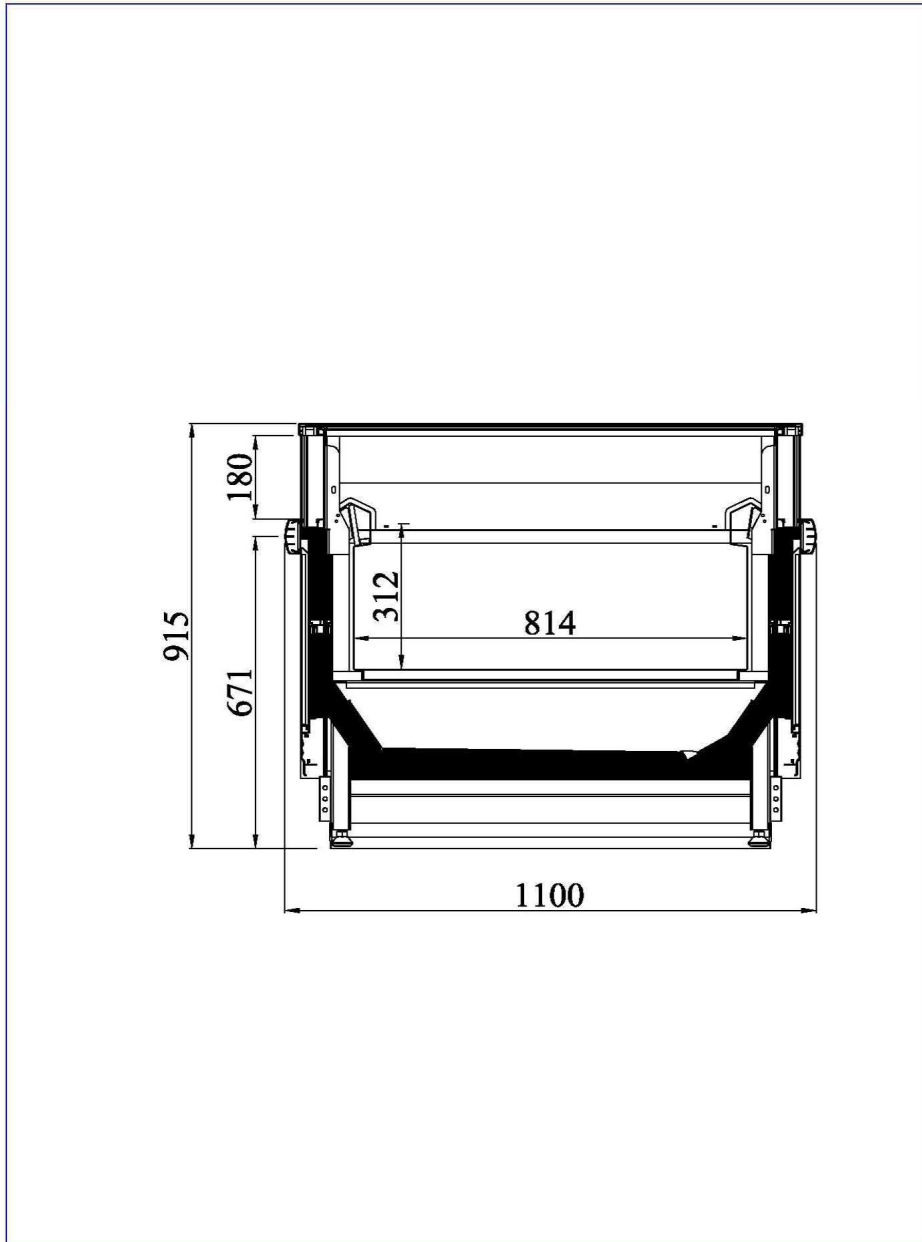

	TECHNICAL DOCUMENTATION	CHAPTER REVISION STATUS					
		ORD.	DATE	CHANGE ORDER	ORD.	DATE	CHANGE ORDER
PRODUCT	KNIDOS	A			D		
DATE of 1st ISSUE	21.11.2006	B			E		
ORDER	U. güröçü	C			F		

	TECHNICAL DATA SHEET - KNIDOS
---	--------------------------------------

TECHNICAL DETAILS	2500	3750
-------------------	------	------

Refrigeration Load		
Case Temp (°C)	-22/-24	
Evap Temp (°C)	-37	
Duty (kW)	1,25	1,875
Expansion Valve (R404)	TES2 Or.02 AKV 10-	TES2 Or.02 AKV 10-
Pipe Size - Suction	5/8"	19 mm
Pipe Size - Liquid	3/8"	3/8"
Pipe Size - Drain	40 mm	
Cubic Capacity (dm ³)	635	952
Display Area (m ²)	2,035	3,052

Defrost Details		
Defrost Type	Electric	
Duration (minutes)	4 x 40	
Termination	Temp	
Defrost Heaters		
Evaporator (Coil)	3 x 800W	3 x 1200W
Water Drain	16W	16W
Front Glass	2 x 50W	2 x 75W
Side Glass	18W (per endwall)	18W (per endwall)
Body	-	-
Air Return	200W	150W x 2
Air Intake	-	-
Electrical / Fans		
Supply	230 V / 50 Hz	
Lighting (T8)	-	-
Evaporator Fans	3 x 42W AO 154 mm/22°	4 x 42W AO 154 mm/22°

Cabinet Controller Setup							
The cabinet was tested with Dixell XR 60C controller							
Parameter	Settings	Parameter	Settings	Parameter	Settings	Parameter	Settings
Set	-32	CF	C	dAF	0	did	15
Hy	1	rES	DE	FnC	0-Y	nPS	15
Ls	-50	Lod	P1	Fnd	0	odc	F-C
Us	110	tdF	EL	Fct	10	PbC	NTC
Ot	0	dtE	30 C	FSt	25	Ptb	4
P2P	Y	Idf	6	ALC	AB		
OE	0	MdF	40	ALU	74,1		
OdS	0	dSd	0	ALL	-50		
AC	0	dFd	DEF	Ald	15		
CCt	0	dAd	0	dAO	1,3		
Con	12	Fdt	0	i1P	CL		
COF	30	dPO	N	i1F	DOR		

Design Conditions			
Temp (°C)	25	Humidity (%)	60
		Cross Draft Air Speed (m/s)	0,2

	TECHNICAL DOCUMENTATION	CHAPTER REVISION STATUS					
		ORD.	DATE	CHANGE ORDER	ORD.	DATE	CHANGE ORDER
PRODUCT	KNIDOS	A			D		
DATE of 1st ISSUE	21.11.2006	B			E		
ORDER	U.GÜDÜCÜ	C			F		

	TECHNICAL DATA SHEET - KNIDOS
---	--------------------------------------

TECHNICAL DETAILS	2500	3750
--------------------------	-------------	-------------

Refrigeration Load		
Case Temp (°C)	-18/-20	
Evap Temp (°C)	-35	
Duty (kW)	1,14	1,71
Expansion Valve (R404)	TES2 Or.02	TES2 Or.02
	AKV 10-	AKV 10-
Pipe Size - Suction	5/8"	19 mm
Pipe Size - Liquid	3/8"	3/8"
Pipe Size - Drain	40 mm	
Cubic Capacity (dm ³)	635	952
Display Area (m ²)	2,035	3,052

Defrost Details		
Defrost Type	Electric	
Duration (minutes)	4 x 40	
Termination	Temp	
Defrost Heaters		
Evaporator (Coil)	3 x 800W	3 x 1200W
Water Drain	16W	16W
Front Glass	2 x 50W	2 x 75W
Side Glass	18W (per endwall)	18W (per endwall)
Body	-	-
Air Return	200W	150W x 2
Air Intake	-	-
Electrical / Fans		
Supply	230 V / 50 Hz	
Lighting (T8)	-	-
Evaporator Fans	3 x 42W AO 154 mm/22°	4 x 42W AO 154 mm/22°

Cabinet Controller Setup							
The cabinet was tested with Dixell XR 60C controller							
Parameter	Settings	Parameter	Settings	Parameter	Settings	Parameter	Settings
Set	-32	CF	C	dAF	0	did	15
Hy	1	rES	DE	FnC	0-Y	nPS	15
Ls	-50	Lod	P1	Fnd	0	odc	F-C
Us	110	tdF	EL	Fct	10	PbC	NTC
Ot	0	dtE	30 C	FSt	25	Ptb	4
P2P	Y	ldf	6	ALC	AB		
OE	0	MdF	40	ALU	74,1		
OdS	0	dSd	0	ALL	-50		
AC	0	dFd	DEF	Ald	15		
CCt	0	dAd	0	dAO	1,3		
Con	12	Fdt	0	l1P	CL		
COF	30	dPO	N	i1F	DOR		

Design Conditions					
Temp (°C)	25	Humidity (%)	60	Cross Draft Air Speed (m/s)	0,2

	 TECHNICAL DOCUMENTATION	CHAPTER REVISION STATUS					
		ORD.	DATE	CHANGE ORDER	ORD.	DATE	CHANGE ORDER
PRODUCT	KNIDOS	A			D		
DATE of 1st ISSUE	21.11.2006	B			E		
ORDER	U.GÜDÜCÜ	C			F		

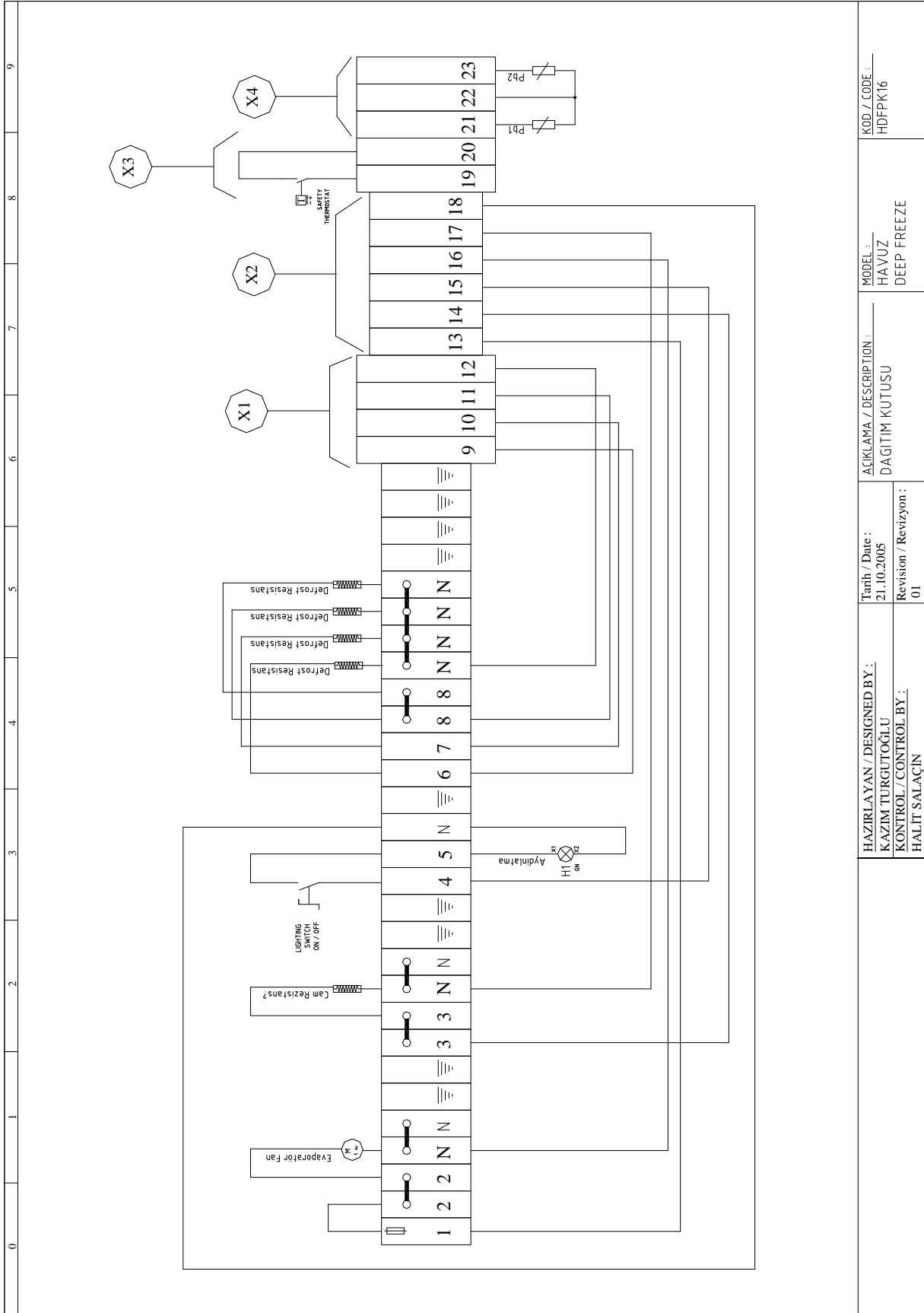

HAZIRLAYAN / DESIGNED BY: KAZIM TURGUTOĞLU	Tarih / Date: 21.10.2005	AÇIKLAMA / DESCRIPTION: DAGITIM KUTUSU	MODEL: HAVUZ DEEP FREEZE	KOD / CODE: HDFPK16
KONTROL / CONTROL BY: HALİT SALAÇIN	Revision / Revizyon: 01			

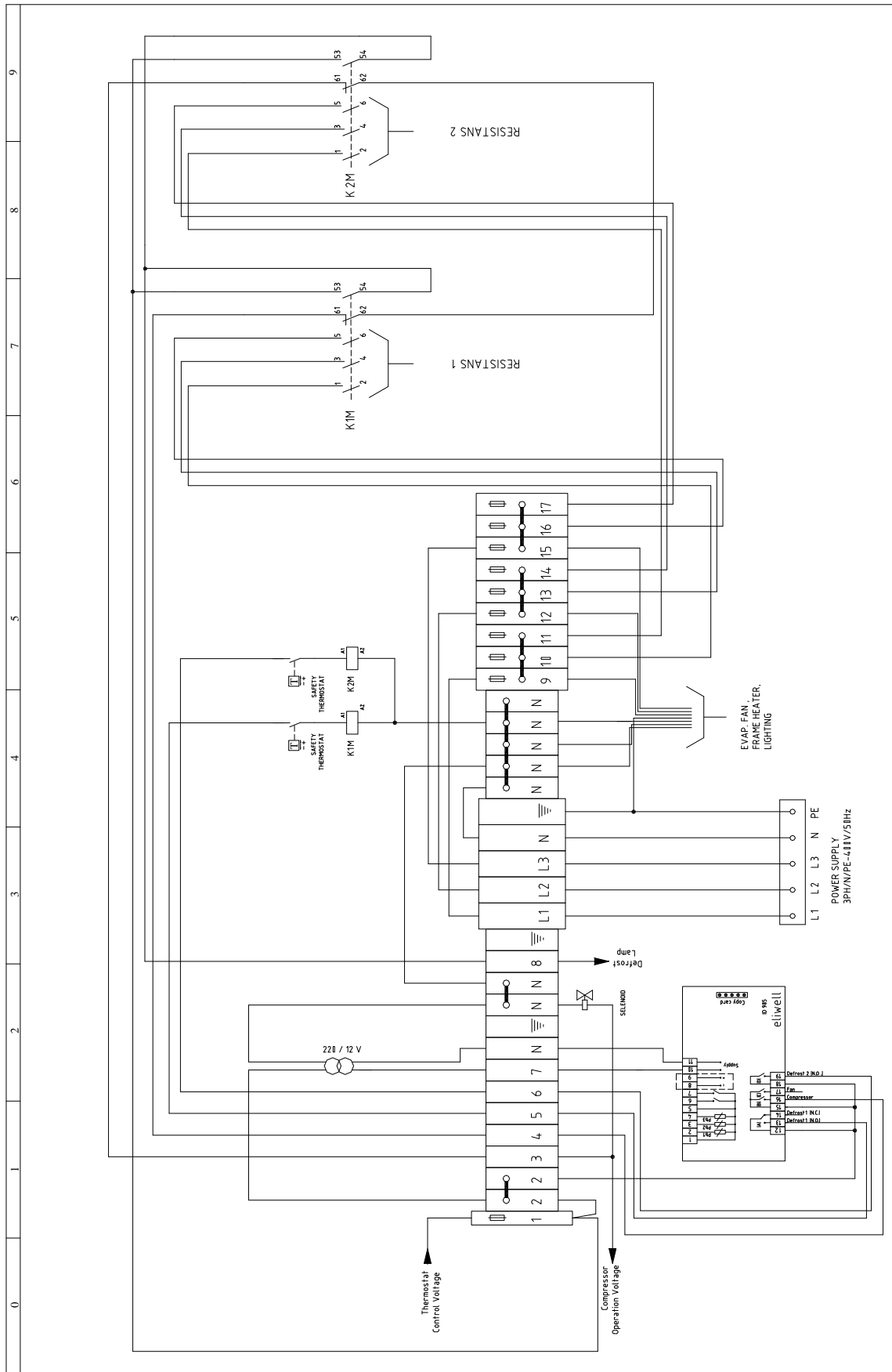

HAZIRLAYAN / DESIGNED BY : KAZIM TURGUTOĞLU	Tarih / Date : 11.10.2005	AKILAMA / DESCRIPTION : PILOT BOX	MODEL : HAYUZ	KOD / CODE : HDFPK15
KONTROL / CONTROL BY : HALİT SALAÇIN	Revision / Revizyon : 00	2 Control with Lighting	DEEP FREEZE	

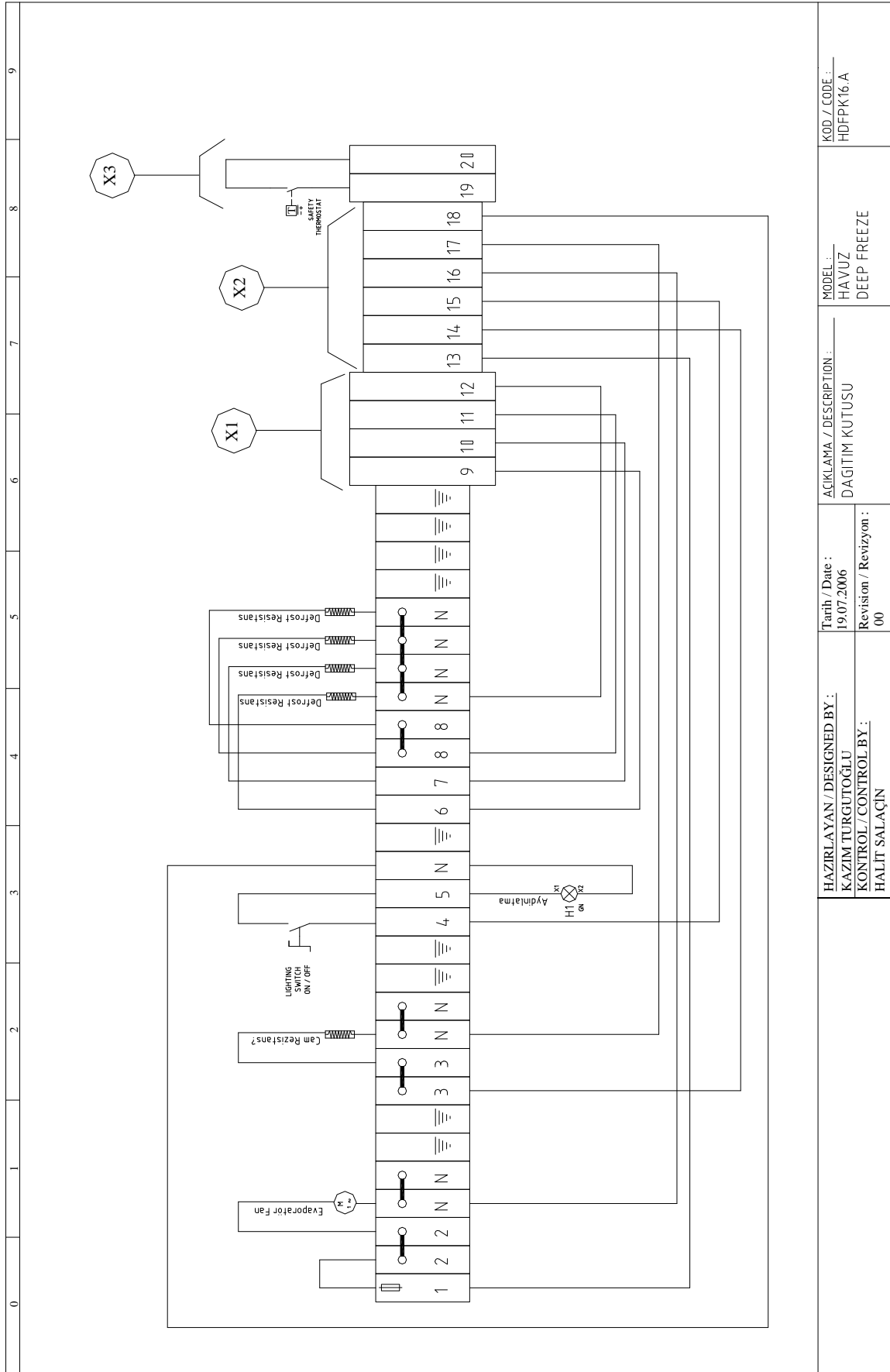

HAZIRLAYAN / DESIGNED BY : KAZIM TURGUTOĞLU	Tarih / Date : 19.07.2006	AÇIKLAMA / DESCRIPTION : DAGITIM KUTUSU	MODEL : HAYUZ DEEP FREEZE	KOD / CODE : HDFPK16 A
KONTROL / CONTROL BY : HALİT SALAÇIN	Revision / Revizyon : 00			

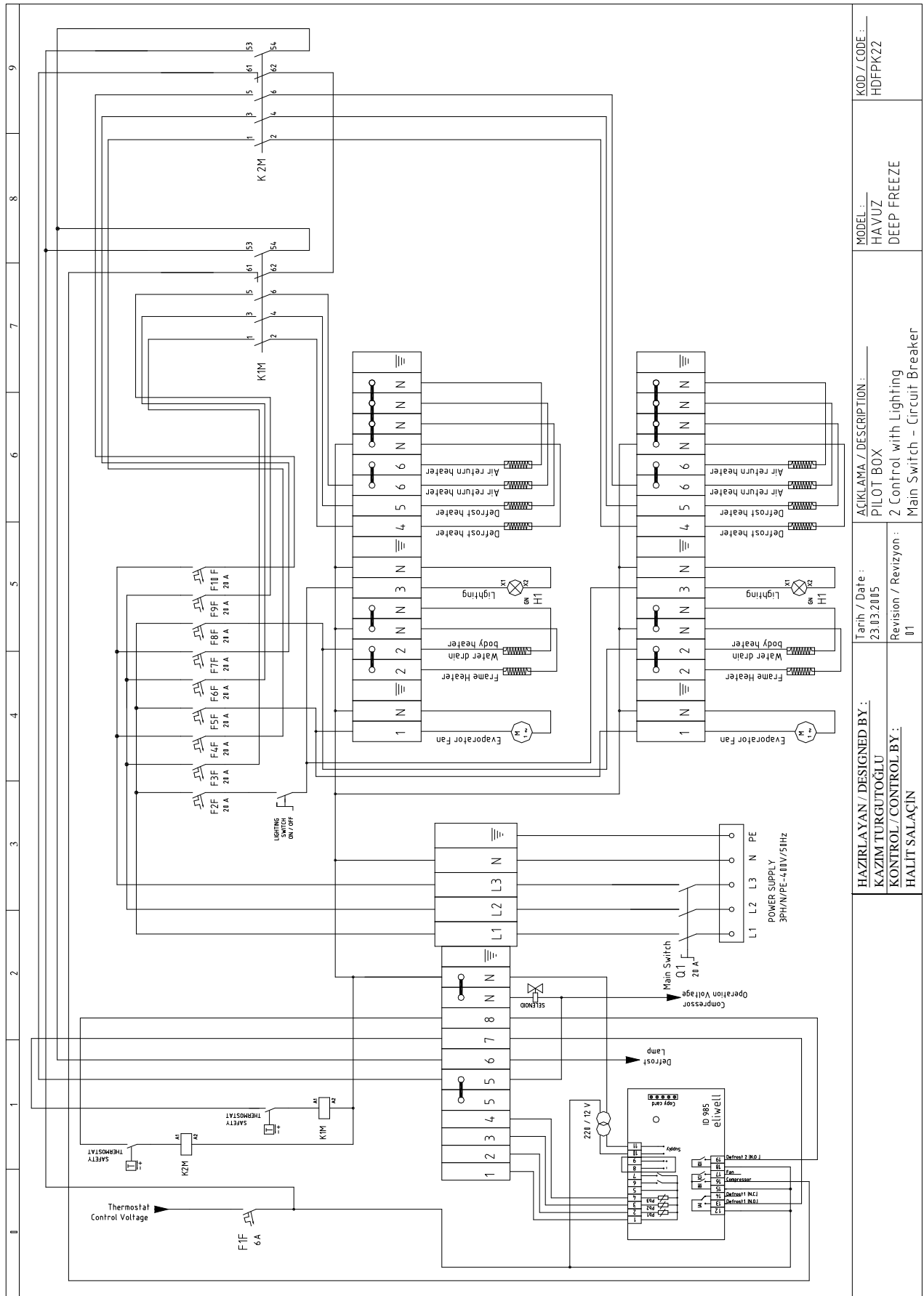

HAZIRLAYAN / DESIGNED BY : KAZIM TURGUTOĞLU	Tarih / Date : 23.03.2015	AÇIKLAMA / DESCRIPTION : PILOT BOX	MODEL : HAVUZ	KOD / CODE : HDFPK22
KONTROL / CONTROL BY : HALİT SALAÇIN	Revision / Revizyon : 01	2 Control with Lighting Main Switch - Circuit Breaker	DEEP FREEZE	

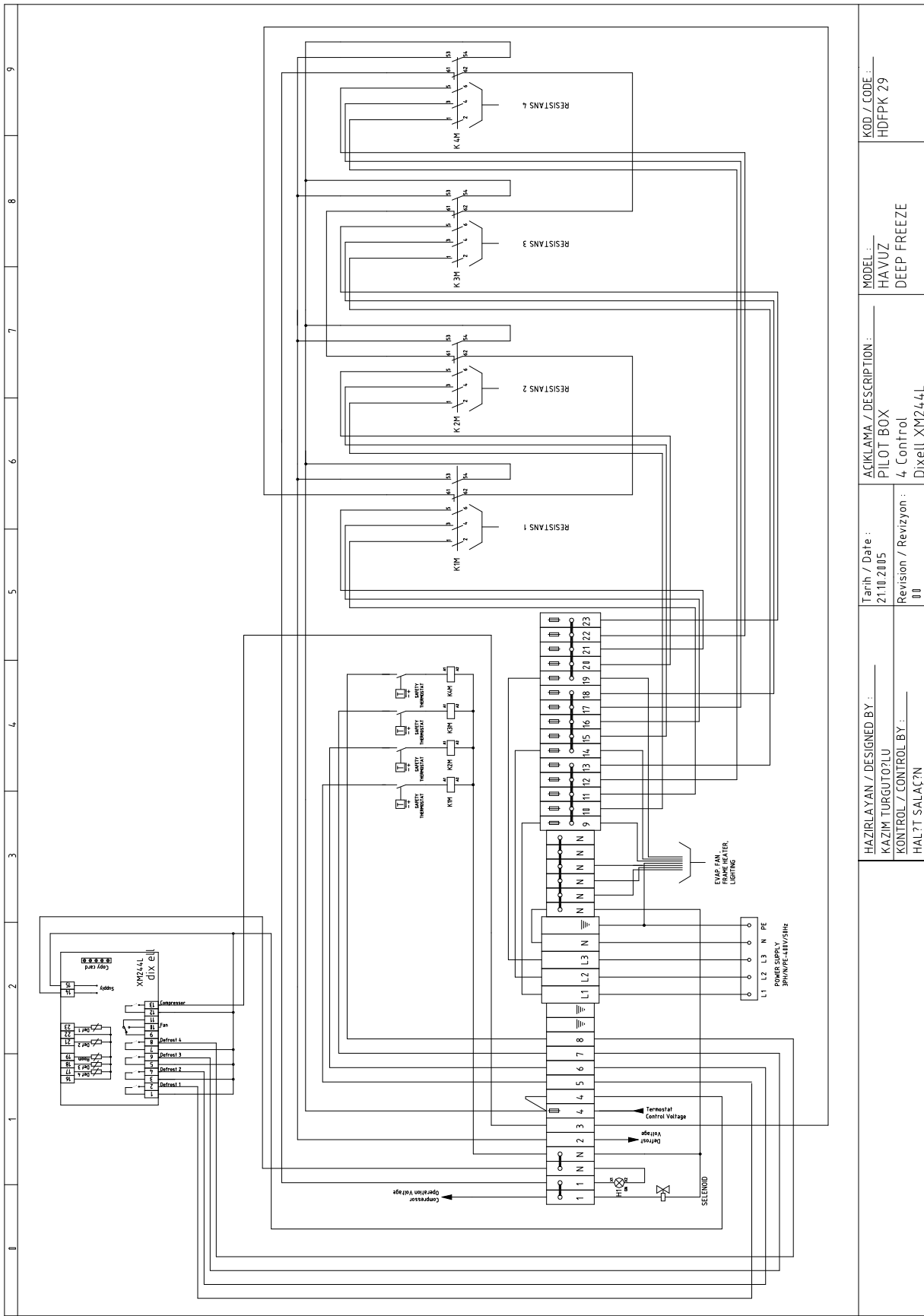

HAZIRLAYAN / DESIGNED BY : KAZIM TURGUTOGLU KONTROL / CONTROL BY : HALIT SALACIN	Tarih / Date : 21.10.2005 Revision / Revizyon : 00	ACIKLAMA / DESCRIPTION : PILOT BOX 4 Control Dixell XM244L	MODEL : HAVUZ DEEP FREEZE	KOD / CODE : HDFPK 29
---	---	---	---------------------------------	--------------------------

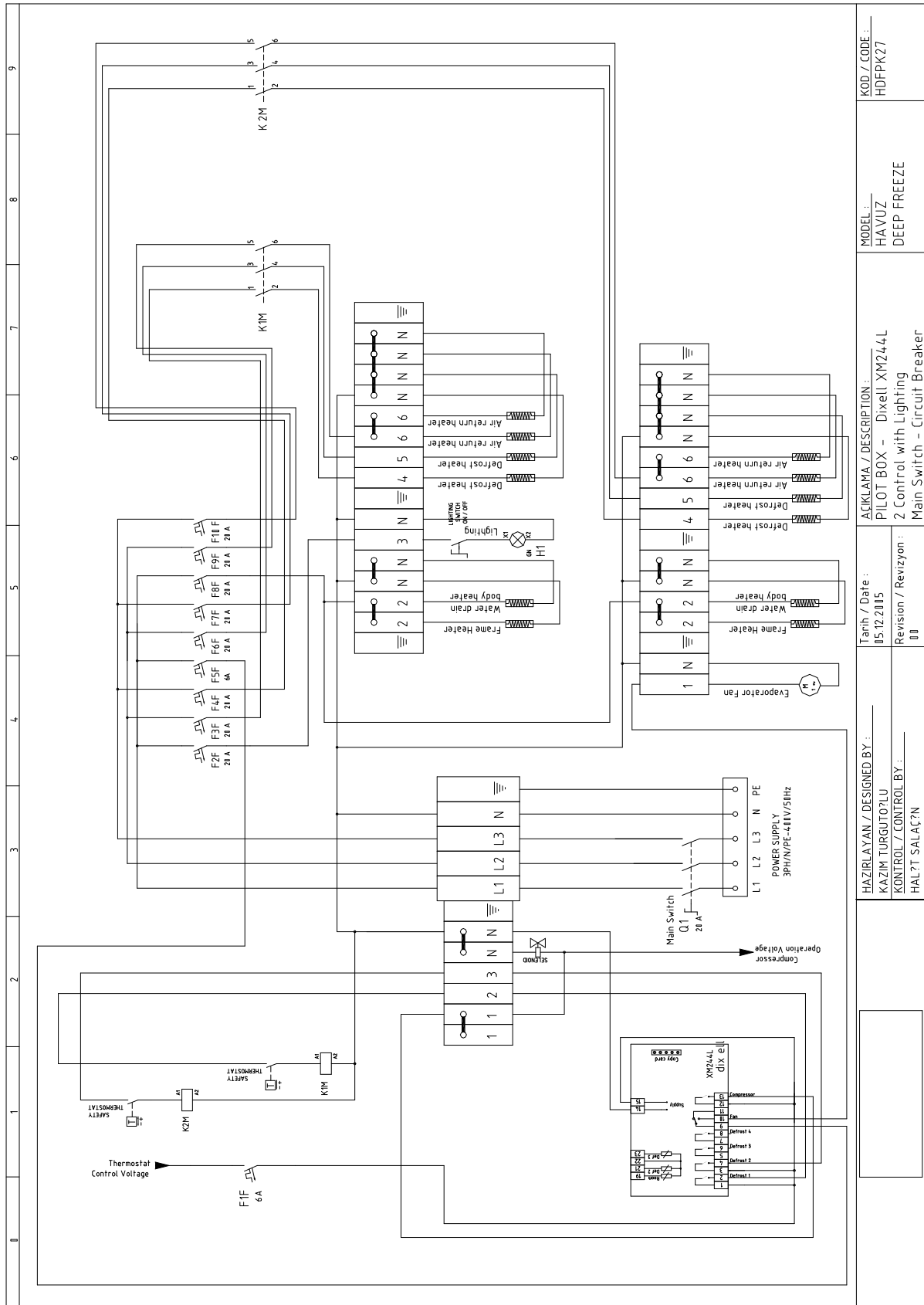

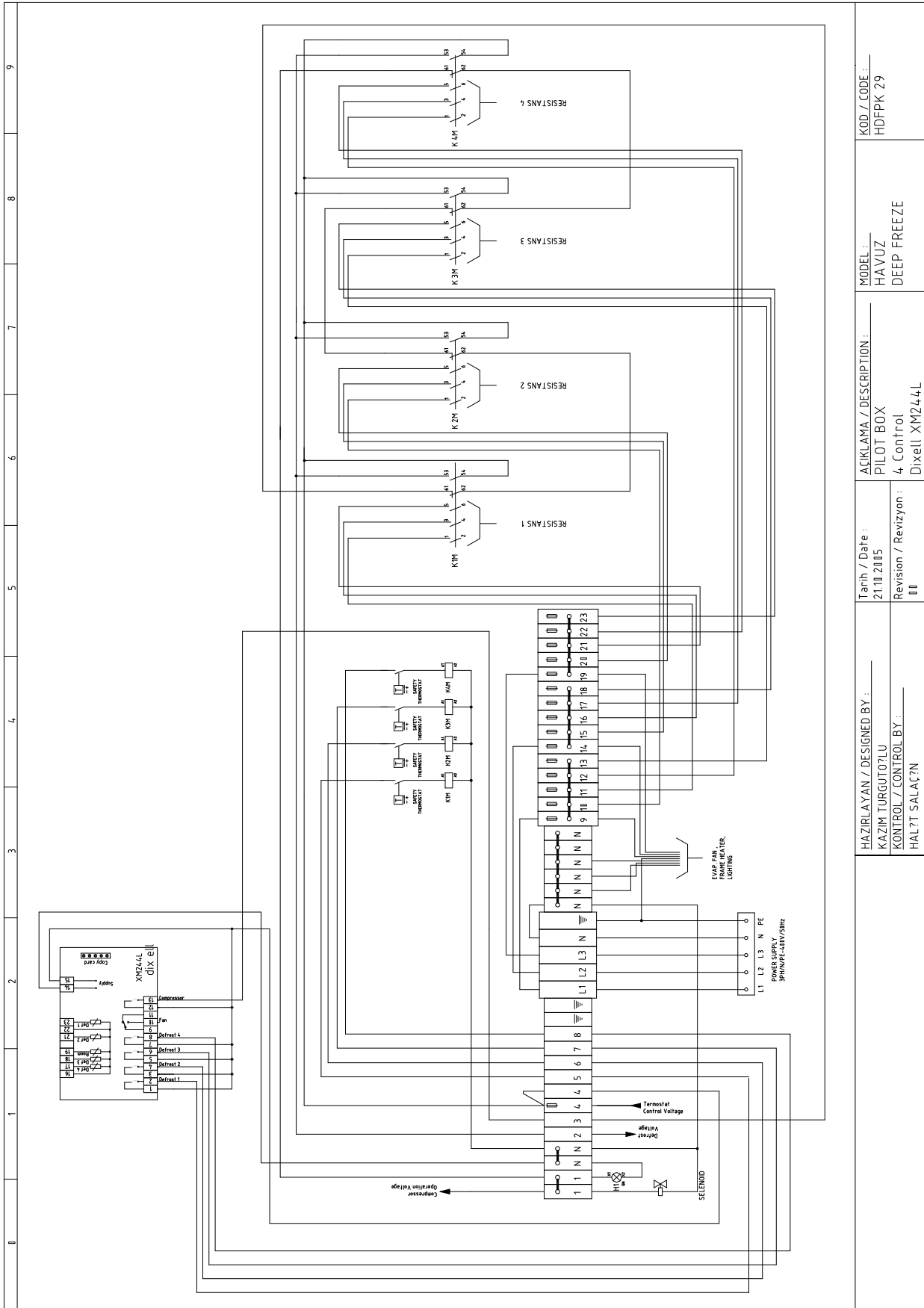

HAZIRLAYAN / DESIGNED BY : KAZIM TURGUTOGLU	Tarih / Date : 21.11.2015	AKILAMA / DESCRIPTION : PILOT BOX	MODEL : HAVUZ	KOD / CODE : HDFPK 29
KONTROL / CONTROL BY : HALIT SALACIN	Revision / Revizyon : 00	4. Control Dixell XM244L	DEEP FREEZE	

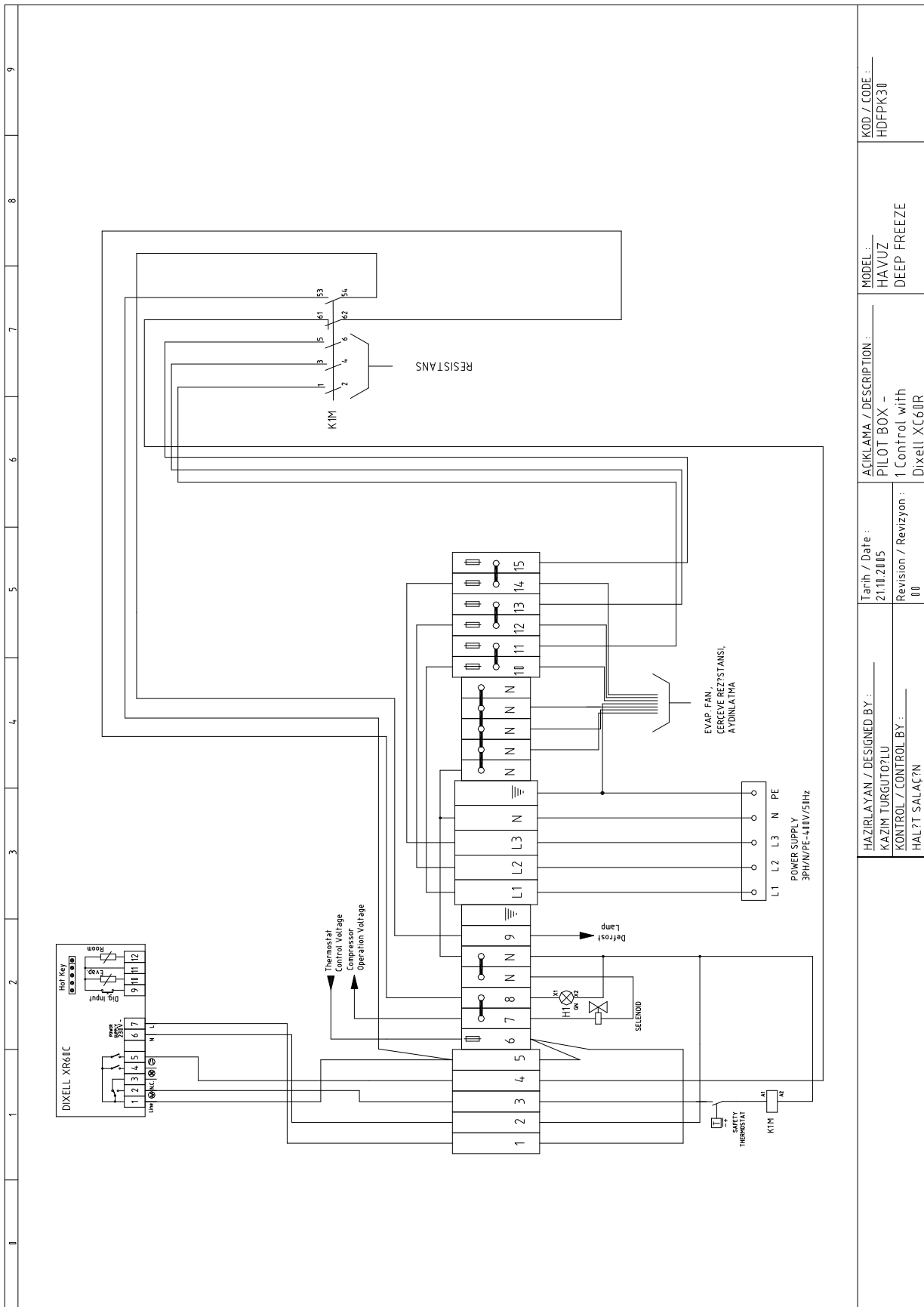

HAZIRLAYAN / DESIGNED BY : KAZIM TURGUTOĞLU KONTROL / CONTROL BY : HALİT SALACIN	Tarih / Date : 21.11.2005 Revision / Revizyon : 00	ACIKLAMA / DESCRIPTION : PILOT BOX - 1 Control with Dixell XC60R	MODEL : HAVUZ DEEP FREEZE	KOD / CODE : HDFPK30
---	---	---	---------------------------------	-------------------------

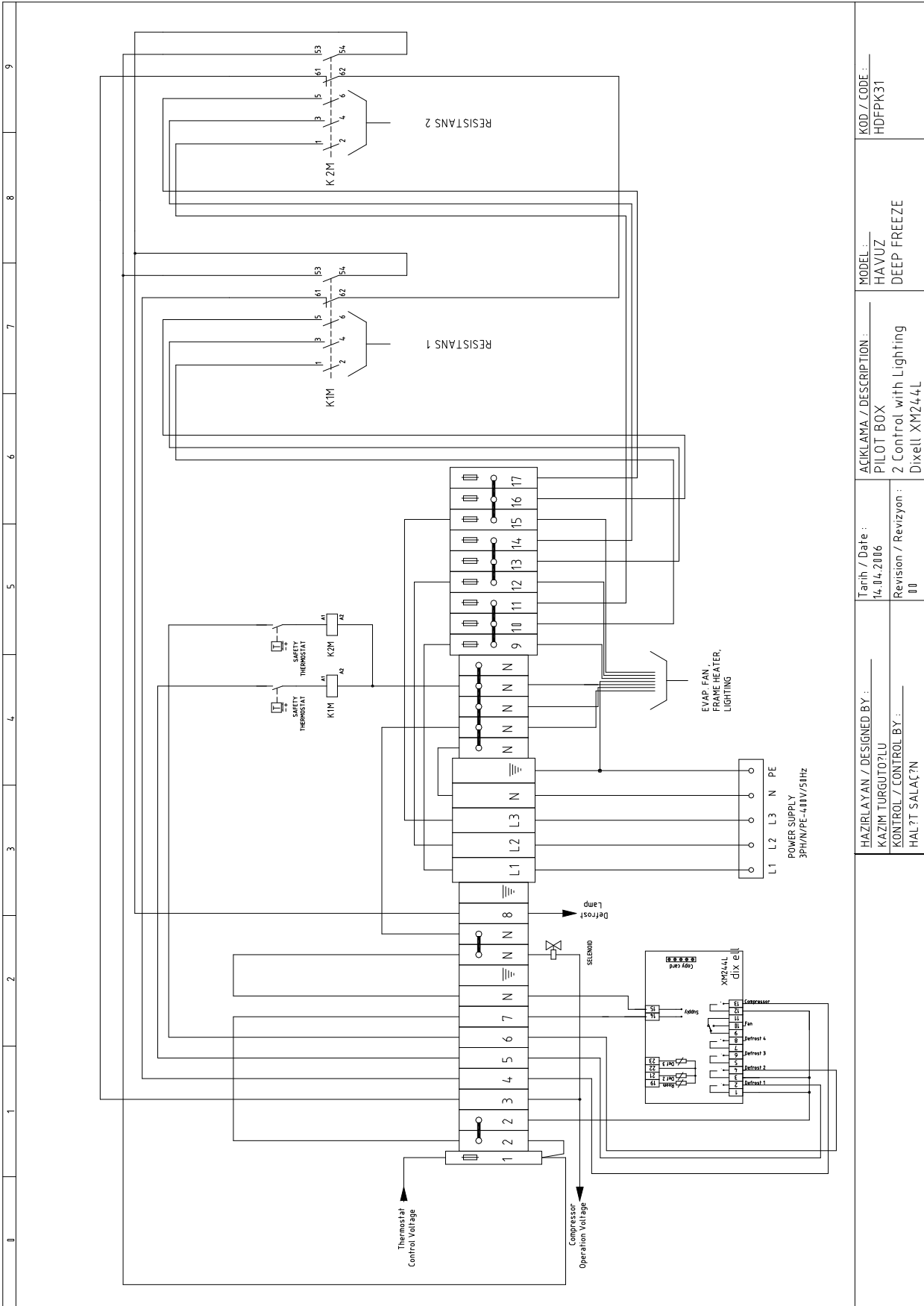

0 1 2 3 4 5 6 7 8 9

HAZIRLAYAN / DESIGNED BY : KAZIM TURGUTOGLU KONTROL / CONTROL BY : HALIT SALATIN	Tarih / Date : 14.04.2006 Revision / Revizyon : 00	AKIKLAMA / DESCRIPTION : PILOT BOX 2 Control with Lighting Dixell XM244L	MODEL : HAYUZ DEEP FREEZE	KOD / CODE : HDFPK31
---	---	---	---------------------------------	-------------------------

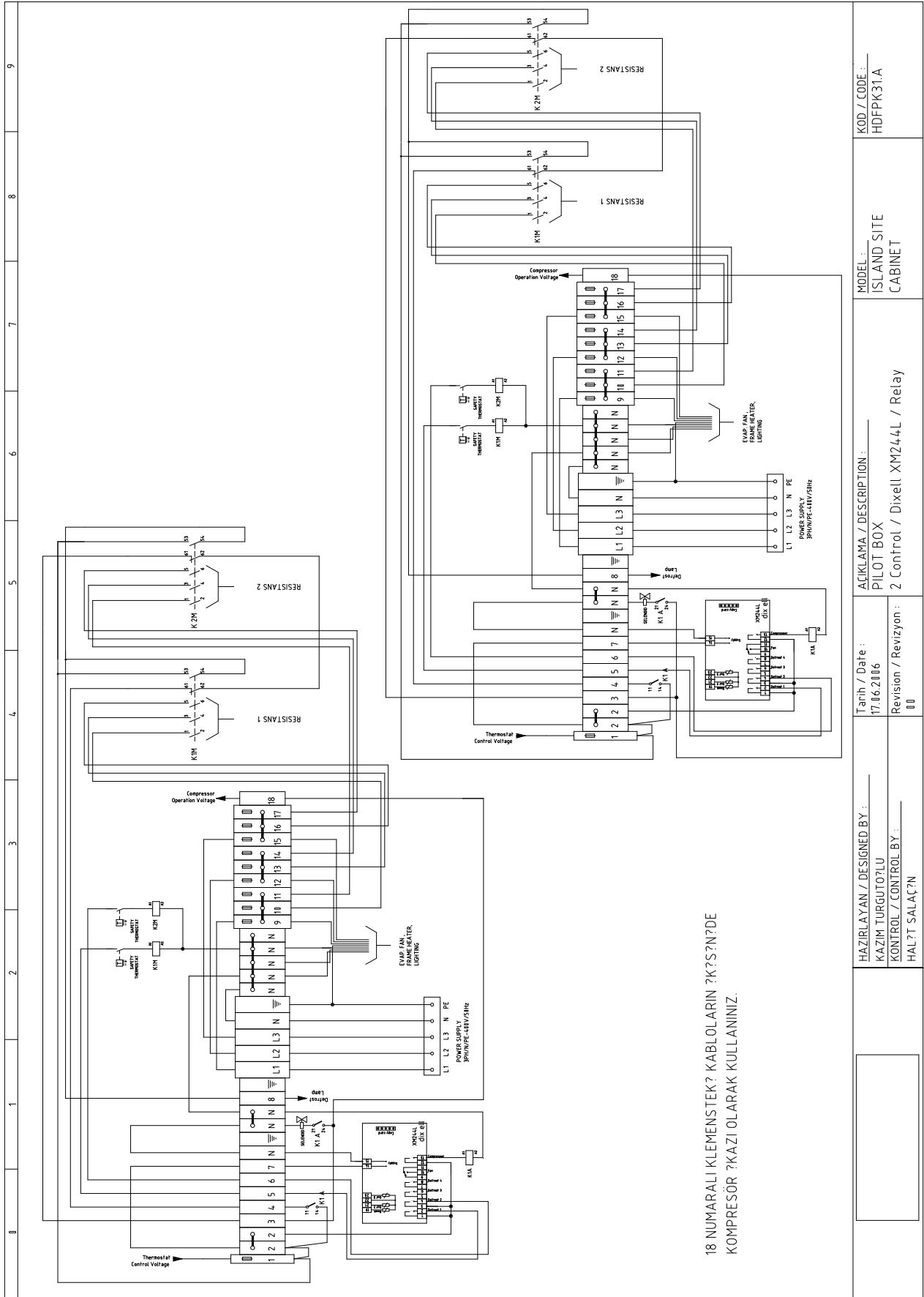

18 NUMARALI KLEMENSTEK? KABLOLARIN ?K?S?N?DE
KOMPRESÖR ?KAZI OLARAK KULLANINIZ.

HAZIRLAYAN / DESIGNED BY : KAZIM TURGUTO?LU KONTROL / CONTROL BY : HAL?T SALAÇ?N	Tarih / Date : 17.06.2016 Revision / Revizyon : 00	ALIKLAMA / DESCRIPTION : PILOT BOX 2 Control / Dixell XM244L / Relay	MODEL : ISLAND SITE CABINET	KOD / CODE : HDFPK31.A
---	---	--	-----------------------------------	---------------------------

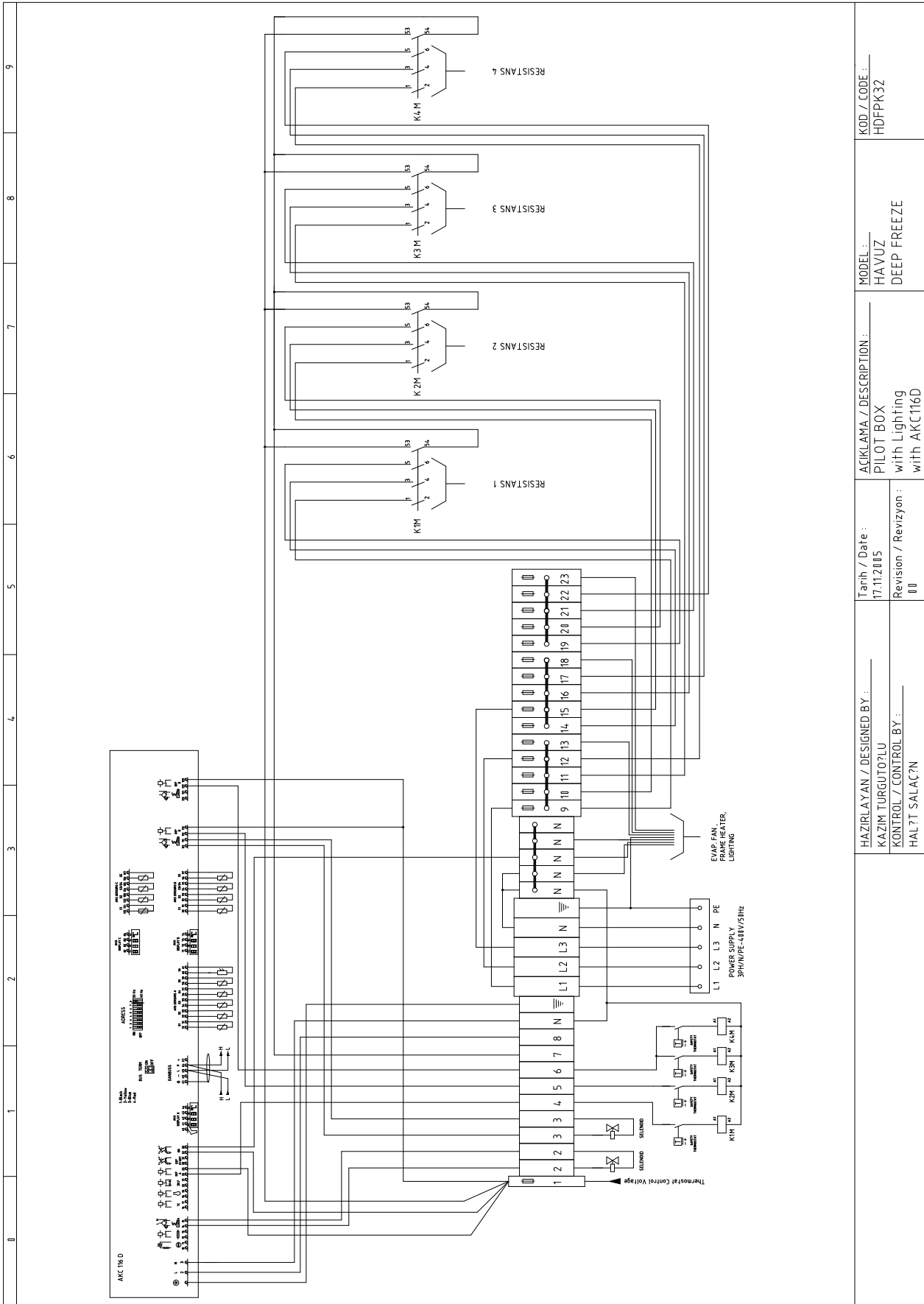

HAZIRLAYAN / DESIGNED BY : KAZIM TURGUTOGLU	Tarih / Date : 17.11.2005	AKILAMA / DESCRIPTION : PILOT BOX with Lighting with AKC116D	MODEL : HAYUZ DEEP FREEZE	KOD / CODE : HDFPK32
KONTROL / CONTROL BY : HALIT SALACIN	Revision / Revizyon : 00			

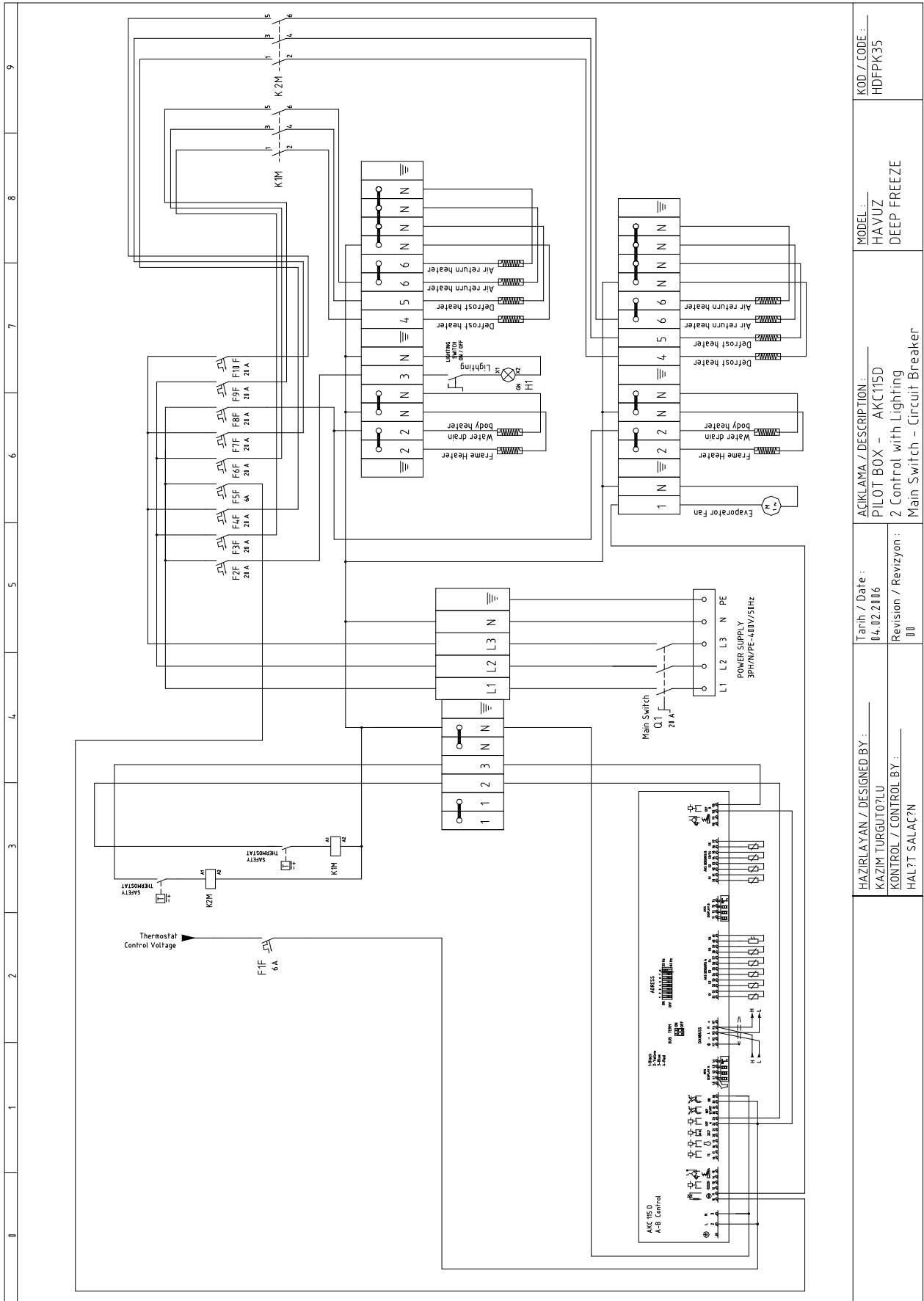

11. Installation and Assembly

This section includes the installation and assembly operations of the product. Before starting the installation and assembly, the user manual of the product should be read thoroughly and the safety-related items specified in the manual should be followed.

Joining Two Refrigerators

Follow the sequence below to combine two or more refrigerators:

- Remove sidewalls (if any)
- Bring the refrigerators side by side and remove the pallets.
- Adjust the height of the legs of the refrigerators and bring their aisles on the same level. Check the accuracy using a water gauge.

Side Strut Connection Installation

Attach the fasteners to the fixing holes on the base plates on the sides of the refrigerator and tighten them with a wrench (Fig.1 and Fig.2). The fasteners to be used and their locations on the refrigerator are shown in Fig.3 and Table.1.

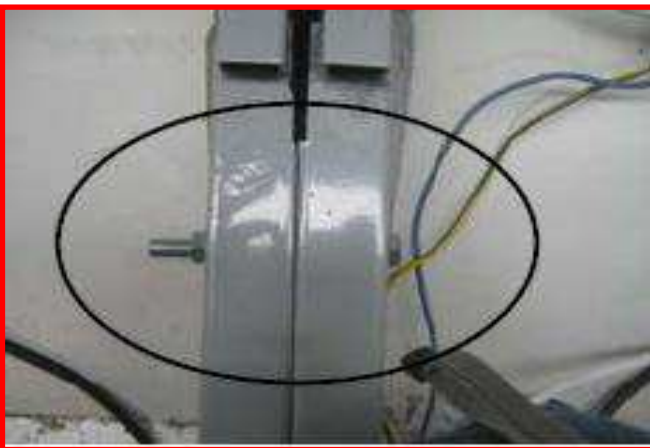

Figure.1



Figure.2

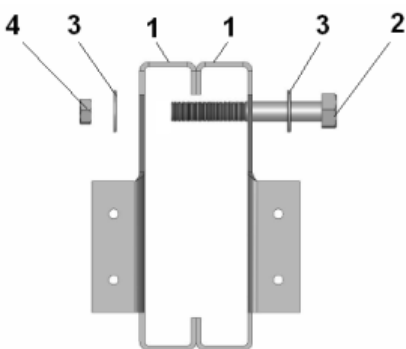

Figure.3
Table.1

NO	PART NAME	PIECES
1	Refrigerator side strut	On the product
2	M10x110 Hex head bolt	2
3	M10 Gasket	4
4	M10 Nut	2

Front Bumper Connections

Fix the refrigerators, which are connected from the side struts, with the help of a cabinet puller piece on the front bumper profiles. Pass the cylinder head bolt through the puller on both refrigerators and tighten with the nut. (Fig.4) Attach the plastic bumper profiles onto the bumper aluminum parts using their lugs. (Fig.5-6-7) The fasteners used and their locations on the refrigerator are shown in Fig.8 and Table.2.



Figure.4



Figure.5



Figure.6



Figure.7

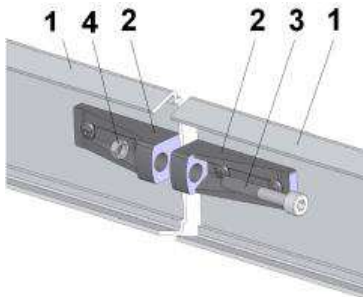

Figure.8

NO	PART NAME	PIECES
1	Bumper aluminum	On the product
2	Cabinet puller	4
3	M8x25 Cylindrical head bolt	2
4	M8 Nut	2

Table.2

Installation of the module joining plastic

The module joining piece should be attached to the junction point of the two refrigerators. Attach the module joining upper and lower pieces via inserting them under and above the refrigerator side struts (Fig. 9-10-11) Then insert the module joining piece onto the glass upper profile. (Figure.12-13)



Figure.9



Figure.10



Figure.11



Figure.12



Figure.13

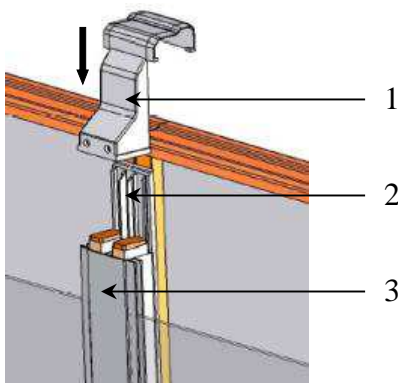

Figure.14

NO	PART NAME
1	Module joining piece
2	Module joining bottom piece
3	Module joining upper piece

Table.3

Installation of Refrigerator Sides

Before attaching the refrigerator sides, apply silicone adhesive to the polyurethane section on the side of the refrigerators. (Fig.15) Fix the sides to the refrigerator at the points indicated by the arrows. (Fig.16-17) The fasteners to be used are shown in Fig.20 and Table.4. Connect the corner bumper plastic to the place shown in Figure.18. Attach the front and side bumper profiles over the bumper aluminum.



Figure.15



Figure.16



Figure.17



Figure.18



Figure.19

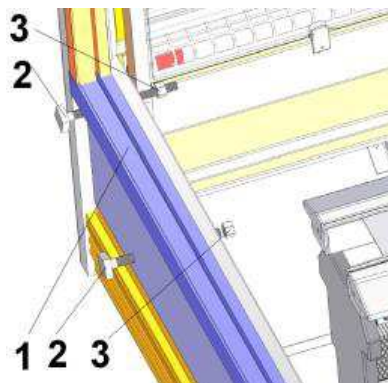

Figure.20

NO	PART NAME	PIECES
1	Refrigerator side	1
2	Plastic stud	4
3	Plastic nut	4

Table.4

Base Assembly

The part under the bottom decoration of the refrigerator cabinets which cover the legs of the refrigerator is called the base. The base is connected to the cabinet legs with the base knob.

Install the front base to the refrigerator first. After inserting the plastic of the plinth on the base, insert the front base to the nails on the foot of the cabinet with the plastic part on the bottom. Place the side base on the front base so that the connection holes coincide as shown in Figure 26. Tighten the base knob by turning it clockwise so that it is in its slot. (Fig.28) Connection elements to be used for the base assembly are shown in Fig.30 and Table.6.



Figure.24



Figure.25



Figure.26



Figure.27



Figure.28



Figure.29

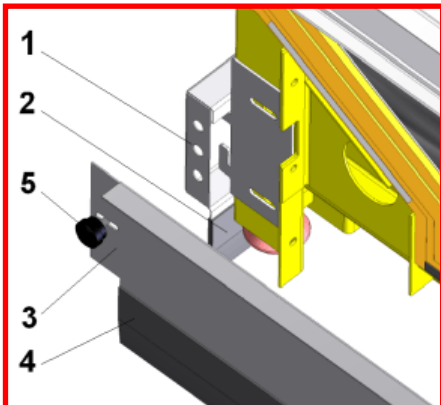

Figure.30

NO	PART NAME	PIECES
1	Front base	On the product
2	Front plinth plastic	1
3	Side base	On the product
4	Side plinth plastic	On the product
5	Base knob	1

Table.6

Display Shelf Assembly

Optionally, you can place single or double rows of uncooled display shelves in Çeşme pool refrigerator.

In order to mount the display shelf in the cabinet, first insert the struts to the places indicated by the arrows in Figure 31. Attach the strut covers numbered 3 to the struts. To connect the fluorescent lamps under the display shelves, push the cable ends over the refrigerator upwards by inserting them through the space under the strut cover. (Figure.33) Remove each of the ends, being one from the other two square holes on the same post. (Figure.34) Thus, the cables are prepared for the electrical connections of the lamps under the shelves. Then, insert the tabs of the shelf arms into the holes on the strut (Figure 35). Layout of the arms shall be as shown in Figure 31, the non-perforated arms should be placed on the outermost side, and the perforated arms should be placed inside so that the cables can pass through. After placing the under shelf traverses numbered 14 between the arms, close the display shelf over the arms (Fig. 36).

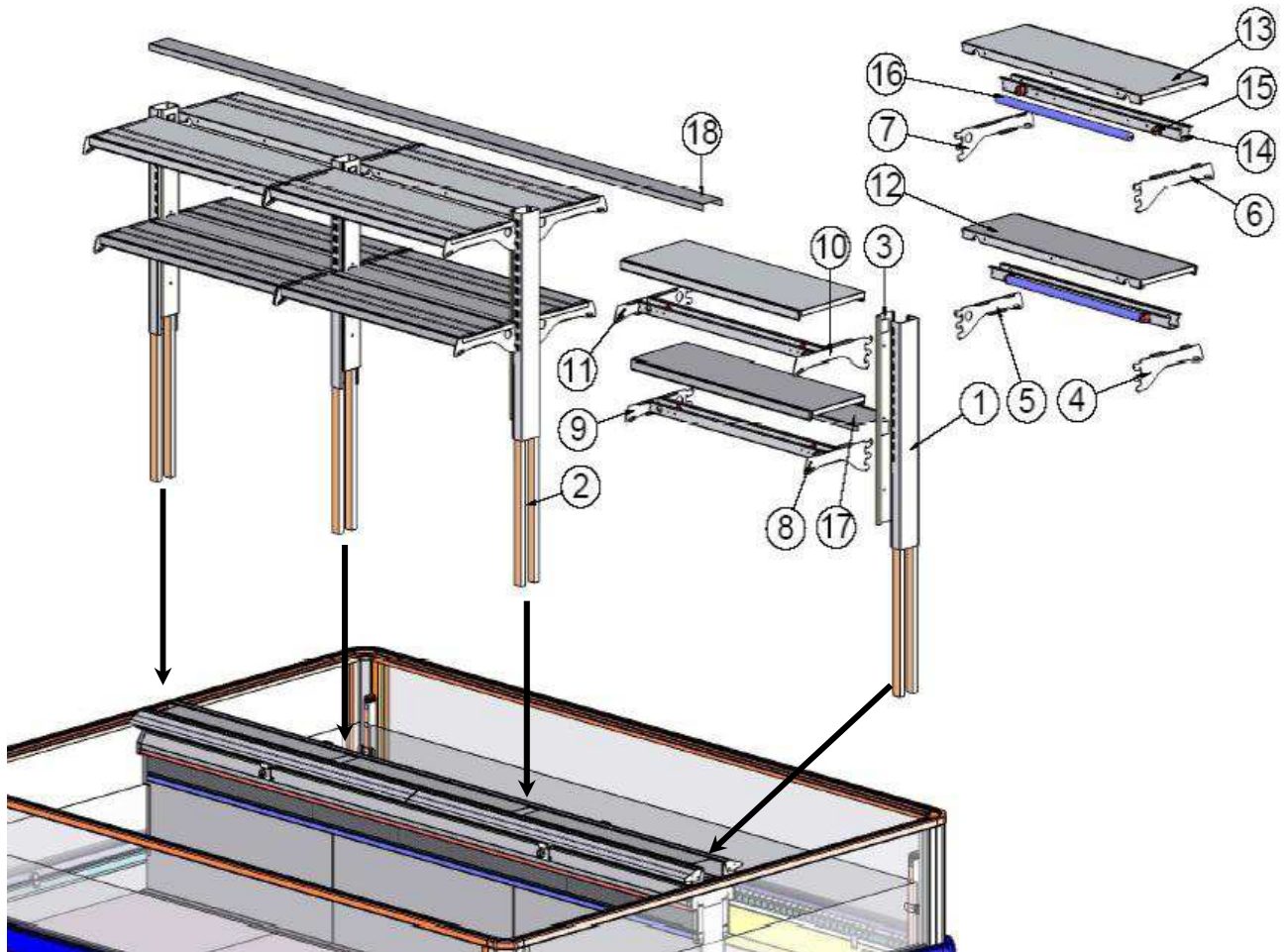

Figure.31



Figure.32



Figure.33

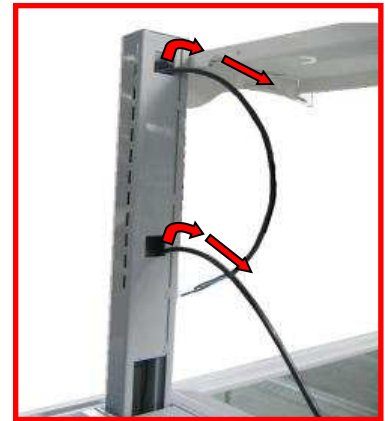

Figure.34



Figure.35



Figure.36

NO	PART NAME	PIECES	
		2500	3750
1	Strut assembly right –left	2	2
2	Strut assembly middle	2	3
3	Strut cover	4	5
4	Left shelf arm 250mm (non-perforated)	1	1
5	Right shelf arm 250mm (perforated)	4	6
6	Left shelf arm 300mm (non-perforated)	1	1
7	Right shelf arm 300mm (perforated)	4	6
8	Left shelf arm 250mm (non-perforated)	1	1
9	Right shelf arm 250mm (perforated)	4	6
10	Left shelf arm 300mm (non-perforated)	1	1
11	Right shelf arm 300mm (perforated)	4	6
12	Display shelf 250mm	3	4

13	Display shelf 300mm	3	4
14	Under-the-shelf traverse	6	8
15	Lamp socket	12	16
16	Fluorescent lamp	6	8
17	Display shelf lower shelf cover plate	3	4
18	Display shelf top shelf cover plate	1	1

Table.7

CAREL PARAMETERS		ISLAND FREEZER	WALL FREEZER	COMBI FREEZER	UPRIGHT FREEZER	COUNTER	MULTIDECK CABINET
/Pro (Prob parameters)							
/2	Measurement stability		4	4	4	4	4
/4	Virtual Prob: Blowing and suction probes rates for regulation		100	100	100	50	50
	0= Blow probe						
	100= Suction probe						
/5	°C or °F selection		0	0	0	0	0
	0=°C, 1=°F						
/6	Decimal		1	1	1	1	1
	0=active,						
	1= inactive						
rHS	Virtual probe regulation rate to calculate glass temperature		20	20	20	20	20
	0= Blow probe						
	100= Suction probe						
/t	Are signals and alarms viewed in non-button terminal?		0	0	0	0	0
	0= inactive						
	1= active						
/t1	probe to be viewed in button terminal		12	12	12	12	12
	0 = Terminal inactive	8 =Serial probe 8					
	1 = Probe 1	9 =Serial probe 9					
	2 = Probe 2	10 =Serial probe 10					
	3 = Probe 3	11 =Serial probe 11					
	4 = Probe 4	12 = Control probe					
	5 = Probe 5	13 = Virtual probe					
	6 = Probe 6	14 = Set point					
	7 = Probe 7						
/t2	probe to be viewed in non-button terminal		12	12	12	12	12
	0 = Terminal inactive	8 =Serial probe 8					
	1 = Probe 1	9 =Serial probe 9					
	2 = Probe 2	10 =Serial probe 10					
	3 = Probe 3	11 =Serial probe 11					
	4 = Probe 4	12 = Control probe					
	5 = Probe 5	13 = Virtual probe					
	6 = Probe 6	14 = Set point					
	7 = Probe 7						

CAREL PARAMETERS			ISLAND FREEZER	WALL FREEZER	COMBI FREEZER	UPRIGHT FREEZER	COUNTER	MULTIDECK CABINET
/to	button/non-button terminal configuration		3	3	3	3	3	3
	Button terminal	Non-button terminal						
	0 Yes	yes						
	1 optional	yes						
	2 Yes	optional						
3 optional	optional							
/P1	S1 ,S2 , S3 (Group 1) probe type		0	0	0	0	0	0
	0 = NTC Standard Range -50T90°C							
	1 = PTC Standard Range -50T150°C							
	2 = PT1000 Standard Range -50T150°C							
	3 = NTCL243 Standard Range -50T90°C							
/P2	S4 ,S5 (Group2) probe type		0	0	0	0	0	0
	0 = NTC Standard Range -50T90°C							
	1 = PTC Standard Range -50T150°C							
	2 = PT1000 Standard Range -50T150°C							
	3 = NTCL243 Standard Range -50T90°C							
/P3	S6 (Group3) probe type		4	4	4	4	4	4
	0 = NTC Standard Range -50T90°C							
	1 = PTC Standard Range -50T150°C							
	2 = PT1000 Standard Range -50T150°C							
	3 = NTCL243 Standard Range -50T90°C							
4 = 0 to 5V ratiometric pressure transmitter								
/P4	S7, (Group4) probe type		0	0	0	0	0	0
	0 = NTC Standard Range -50T90°C							
	1 = PTC Standard Range -50T150°C							
	2 = PT1000 Standard Range -50T150°C							
	3 = NTCL243 Standard Range -50T90°C							
	4 = 0 to 5V ratiometric pressure transmitter							
	5 = 0 to 10 V input							
6 = 4 to 20 mA input								
/P5	S8 den S11 e (Group5) serial problar probe type		0	0	0	0	0	0

CAREL PARAMETERS			ISLAND FREEZER	WALL FREEZER	COMBI FREEZER	UPRIGHT FREEZER	COUNTER	MULTIDECK CABINET
CtL (Control)								
OFF	ON/OFF control unit on-off		0	0	0	0	0	0
	0 = ON; 1 = OFF;							
St	Set point		-20	-20	-20	-20	0	2
St2	Double thermostate control suction set value		50	50	50	50	50	50
rd	St set value difference		2	2	2	2	2	2
rd2	Double thermostate control suction set value difference		0	0	0	0	0	0
	0.0 = Function inactive							
r1	Allowed minimum set value		-24	-24	-24	-24	-4	-4
r2	Allowed maximum set value		-18	-18	-18	-18	4	4
r3	Defrost warning activation ending in time		0	0	0	0	0	0
	0 = inactive, 1 = active							
r4	Automatic night set point		0	0	0	0	0	0
r5	Will minimum and maximum temperatures be kept to which probe in the memory?		1	1	1	1	1	1
	0 = Monitoring inactive	6 = superheat temperature probe (tGS)						
	1 = Control probe (Sreg)	7 = saturated evaporation temperature probe (tEu)						
	2 = virtual probe (Sv)	8 = auxiliary defrost probe (Sd2)						
	3 = Blow probe (Sm)	9 = auxiliary probe (Saux)						
	4 = defrost probe (Sd)	10 = auxiliary probe 2 (Saux2)						
rt	Recorded min and max temperature monitoring time range		-	-	-	-	-	-
rH	Recorded max temperature		-	-	-	-	-	-
rL	Recorded min temperature		-	-	-	-	-	-
r6	Night Control probe		0	0	0	0	0	0
	0 = virtual probe Sv; 1 = Suction probe Sr							
ro	For Virtual Probe, probe error offset		0.0	0.0	0.0	0.0	0.0	0.0
r7	Master solenoid valve configuration		0	0	0	0	0	0
	0 = local valve ;1 = network valve (connected to the Master)							
rSu			0	0	0	0	0	0

CAREL PARAMETERS			ISLAND FREEZER	WALL FREEZER	COMBI FREEZER	UPRIGHT FREEZER	COUNTER	MULTIDECK CABINET
CMP (compressor)								
c0	Compressor and fan starting time delay		0	0	0	0	0	0
c1	Minimum time between successive start		0	0	0	0	0	0
c2	Compressor minimum OFF Time		0	0	0	0	0	0
c3	Compressor minimum ON Time		0	0	0	0	0	0
c4	Control probe error duty time. Compressor and solenoid outlet works for the time stated there		0	0	0	0	0	0
	holds for 15 minutes and works again.							
	0 = Compressor/valve always OFF; 100 = compressor/valve always ON							
cc	Continuous cycle time		1	1	1	1	1	1
c6	Post-continuous cycle alarm by-pass		60	60	60	60	60	60
c7	Maximum pump down time		0	0	0	0	0	0
Def (defrost)								
d0	Defrost type		4	0	0	0	0	0
	0 =temperature-based heater							
	1 = temperature-based hot gas							
	2 = temperature-based heater							
	3 = time-based hot gas							
4 =time and temperature-based heater defrost								
5 =temperature-based heater multiplied hotgas bypass								
6 =time-based heater multiplied hotgas bypass								
d2	Defrost-end synchronization by Master		1	1	1	1	1	1
	0 = unsynchronous; 1 = synchronous							
dl	Time between defrosts		8	8	6	6	6	6
dt1	Defrost-end temperature, Evaporator Sd1		10	10	12	12	10	10
dt2	Defrost-end temperature,AUX Evaporator Sd2		10	10	12	12	10	10
dP1	Maximum Defrost time		35	35	40	45	45	45
dP2	Maximum Defrost time, AUX 2. Evaporator		35	35	40	45	45	45
d4	Initially defrost		0	0	0	0	0	0
	0 = No initial defrost ; 1 = inital defrost							
	(Master = network defrost; Slave = local defrost)							
d5	Defrost time delay at the beginning if d4=1		0	0	0	0	0	0
	0 = delay inactive							
d6	Terminal indicator status during defrost		2	2	2	2	2	2
	0 = Real temperature value and "dEF" flashes							
	1 = pre-defrost last temperature remains on the screen							
	2 = 'dEF' is viewed							
dd	Post-Defrost drip time		2	2	2	2	2	2
	0= No drip							

CAREL PARAMETERS		ISLAND FREEZER	WALL FREEZER	COMBI FREEZER	UPRIGHT FREEZER	COUNTER	MULTIDECK CABINET	
d7	defrost by-pass	0	0	0	0	0	0	
	0 = inactive ; 1 = active;							
d8	Alarm delay following defrost and door opening	30	30	30	30	30	30	
d9	Status of compressor protection times in hotgas bypass	1	1	1	1	1	1	
	0 = protection times are followed ; 1 = protection times are ignored							
Sd1	Defrost Probe value	-	-	-	-	-	-	
Sd2	Second Evaporator defrost probe value	-	-	-	-	-	-	
dC	Defrost time basis	0	0	0	0	0	0	
	0 = dl hour,dP1,dP2 and ddP minute; 1 = dl minute,Dp2 and ddP second							
d10	Time for defrost based on lamel temperature	0	0	0	0	0	0	
	0 = Function inactive							
d11	Temperature-based defrost activation temperature threshold	-30	-30	-30	-30	-30	-30	
d12	During Defrost, pressure transmitter alarm status		0	0	0	0	0	
	probe failure	failure in supervisor						
	0 inactive	active						
	1 active	active						
	2 inactive	inactive						
3 active	inactive							
dS1	Compressor stop time for successive defrost (when stops for this time, defrost ends,	0	0	0	0	0	0	
	0 = Function inactive							
dS2	Compressor operation time for successive defrost (defrost starts when the	120	120	120	120	120	120	
ddt	Defrost end temperature offset for Power defrost	0.0	0.0	0.0	0.0	0.0	0.0	
ddp	Defrost time offset for Power defrost	0	0	0	0	0	0	
dn	Nominal Defrost bypass time rate	75	75	75	75	75	75	
d1S	daily defrost based on td1 time zone	0	0	0	0	0	0	
	0 = inactive							8 = 3 hours 0 minute
	1 = 24 hours 0 minute							9 = 2 hours 40 minutes
	2 = 12 hours 0 minute							10 = 2 hours 24 minutes
	3 = 8 hours 0 minute							11 = 2 hours 11 minutes
	4 = 6 hours 0 minute							12 = 2 hours 0 minute
	5 = 4 hours 48 minutes							13 = 1 hour 0 minute
	6 = 4 hours 0 minute							14 = 30 minutes
7 = 3 hours 26 minutes								

CAREL PARAMETERS		ISLAND FREEZER	WALL FREEZER	COMBI FREEZER	UPRIGHT FREEZER	COUNTER	MULTIDECK CABINET
d2S	see d1S parameter for td1 time zone daily defrosts	0	0	0	0	0	0
dH1	Pumpdown time	0	0	0	0	0	0
	0= pump down inactive						
dHG	Multiplied hot gas bypass type	0	0	0	0	0	0
	0 = Compensator valve is OFF usually						
	1 = Compensator valve is ON usually						
ALM (Alarm)							
AA	Determination of temperature probe for AH and AL alarms		1	1	1	1	1
	1 = control (sreg)	8 = auxiliary defrost probe (Sd2)					
	2 = virtual (Sv)	9 = auxiliary probe (Saux)					
	3 = blow (Sm)	10 = auxiliary probe 2 (Saux2)					
	4 = defrost (Sd)	11 = ortam sıcaklığı (SA)					
	5 = suction (Sr)	12 = ortam nemi (SU)					
	6 = superheat temperature probe(tGS)	13 = cam sıcaklığı (Syt)					
	7 =SH pressure transmitter temperature equivalence (tEu)	14 = çığırma noktası (SdP)					
AA2	Determination of temperature probe for AH2 and AL2 alarms control AA parameter		5	5	5	5	5
A0	Low and high temperature alarm difference		2.0	2.0	2.0	2.0	2.0
A1	Threshold type for AL and AH 1. Alarm delays		0	0	0	0	0
	0 = relative AL and AH set value 1 = absolute AL and AH absolute values						
A2	Threshold type for AL2 and AH2 2. Alarm delays		0	0	0	0	0
	0 = relative AL and AH set value 1 = absolute AL and AH finite values						
AL	Low temperature 1. alarm threshold		4	4	4	4	4
AH	High temperature 1. alarm threshold		5	5	5	5	5
AL2	Low temperature 2. alarm threshold		0	0	0	0	0
AH2	High Temperature 2. alarm threshold		0	0	0	0	0
Ad	Low and high temperature alarm alarm delay		15	15	15	15	15
A4	ID1 digital input configuration in S4 input		0	0	0	0	0
	0 = input is not active	5 = kapı switci konfigürasyonu kompresör ve fanlar OFF					
	1 = momentary external alarm	6 = uzaktan ON/OFF					
	2 = delayed external alarm	7 = perde switchi					
	3 = defrost activation	8 = sürekli çevrim başlama / durma					
	4 = defrost starting	9 = ışık sensörü					

CAREL PARAMETERS		ISLAND FREEZER	WALL FREEZER	COMBI FREEZER	UPRIGHT FREEZER	COUNTER	MULTIDECK CABINET
A5	ID2 digital input configuration in S5 input, see the list in A4 parameter	0	0	0	0	0	0
A6	In the event of external alarm, solenoid/compressor working times. Compressor and solenoid work for this time, stop for 15 minutes and work againn.	0	0	0	0	0	0
	0 = Compressor/valve always OFF; 100 = compressor/valve always ON						
A7	Time delay for delayed external alarm	0	0	0	0	0	0
A8	Virtual digital input configuration see the list in A4 parameter	0	0	0	0	0	0
A09	Digital input selection transferred from master to slave		0	0	0	0	0
	0 = supervisor	3 = D13					
	1 = D11	4 = D14					
	2 = D12	5 = D15					
A10	ID3 digital input configuration in S6 input see the list in A4 parameter	0	0	0	0	0	0
A11	Id4 digital input configuration in S7 input, see the list in A4 parameter	0	0	0	0	0	0
A12	Digital input configuration in D15 input, see the list in A4 parameter	0	0	0	0	0	0
Ar	Is alarm signal in slaves shown in master?	1	1	1	1	1	1
	0 = no ; 1 = yes						
A13	When slaves are offline, hotgas bypass procedure	0	0	0	0	0	0
	0 = inactive 1 = active						
Fan (Evaporator fans)							
F0	Evaporator fan management	0	0	0	0	0	0
	0 = always ON						
	1 = Fan activation Sd defrost - Sv virtual (or Sd defrost - Sm blow double thermostat control) 2 =Activation Sd defrost probe						
F1	Fan activation threshold (only F0=1 and 2)	-5.0	-5.0	-5.0	-5.0	-5.0	-5.0
F2	Will fans stop when the compressor stops?	0	0	0	0	0	0
	0 =Fans work 1 = Fans stop						
F3	Status of fans during defrost	0	0	1	1	0	0
	0 = Fans work in Defrost 1 = fans stop						
Fd	Post-defrost drip fan waiting time	2	2	2	2	2	2
Frd	Fan activation difference (including variable speed fans)	2.0	2.0	2.0	2.0	2.0	2.0
F5	Evaporator fan stop threshold (difference 1C)	50.0	50.0	50.0	50.0	50.0	50.0
F6	Maximum Evaporator fan speed	100	100	100	100	100	100

CAREL PARAMETERS		ISLAND FREEZER	WALL FREEZER	COMBI FREEZER	UPRIGHT FREEZER	COUNTER	MULTIDECK CABINET
F7	Minimum Evaporator fan speed	0	0	0	0	0	0
F8	Evaporator fan peak time	0	0	0	0	0	0
	0 = Function inactive						
F9	PWM1/' fan control output selection (by phase-break)	1	1	1	1	1	1
	0 = pulse 1 = time-dependant						
F10	Time of working of evaporator fans at maximum speed	0	0	0	0	0	0
	0 = Function inactive						
Eud (Electronic valve)							
P1	Electronic valve	2	2	2	2	2	2
	0 = not used 1 = PWM valve 2 = CAREL E2V valve						
P3	Superheat Set point	10.0	10.0	10.0	10.0	10.0	10.0
P4	Proportional rate	15.0	15.0	15.0	15.0	15.0	15.0
P5	Integration rate (Integral factor)	150	150	150	150	150	150
	0 = Function inactive						
P6	Derivative rate	5.0	5.0	5.0	5.0	5.0	5.0
	0 = Function inactive						
P7	LowSH: low superheat threshold	7.0	7.0	7.0	7.0	7.0	7.0
P8	LowSH: low superheat integral time	15.0	15.0	15.0	15.0	15.0	15.0
	0 = Function inactive						
P9	LowSH: düşük superheat alarm gecikmesi	600	600	600	600	600	600
	0 = alarm inactive						
P10	Will solenoid valve be OFF in the event of low superheat or low suction temperature?	0	0	0	0	0	0
	1 = OFF is active						
P11	LSA: low evaporation temperature alarm	-45.0	-45.0	-45.0	-45.0	-45.0	-45.0
P12	LSA: alarm delay	600	600	600	600	600	600
	0 = alarm inactive						
P13	LSA: alarm difference (C)	10.0	10.0	10.0	10.0	10.0	10.0
	0 = reset the alarm all the time automatically						
P14	('blo') alarm signal activation	1	1	1	1	1	1
	1= blo alarm is active						
P15	Complementary temperature acceptance value in the event of Superheat pressure	-30	-30	-30	-12	-12	-12

CAREL PARAMETERS			ISLAND FREEZER	WALL FREEZER	COMBI FREEZER	UPRIGHT FREEZER	COUNTER	MULTIDECK CABINET
PH	Gas type		3	3	3	3	3	3
	1 = R22	8 = R600						
	2 = R134a	9 = R600a						
	3 = R404A	10 = R717						
	4 = R407C	11 = R744						
	5 = R410A	12 = R728						
	6 = R507A	13 = R1270						
	7 = R290	14 = R417A						
OSH	Superheat offset for modulation thermostate		0.0	0.0	0.0	0.0	0.0	0.0
	0 = Function inactive							
Phr	Fast updating of valve parameters by the supervisor		0	0	0	0	0	0
	0 = fast update is inactive							
PM1	MOP: Maximum evaporation pressure temperature value		50.0	50.0	50.0	50.0	50.0	50.0
PM2	MOP: Integral time		10.0	10.0	10.0	10.0	10.0	10.0
PM3	MOP: alarm delay		0	0	0	0	0	0
	0 = Function is inactive							
PM4	MOP: MOP function delay at the beginning		2	2	2	2	2	2
PM5	MOP: activating solenoid valve shutting		0	0	0	0	0	0
	0 = OFF is inactive							
	1 = OFF is active							
PL1	LOP: Minimum evaporation pressure temperature value		-50.0	-50.0	-50.0	-50.0	-50.0	-50.0
PL2	LOP: Integral time		0.0	0.0	0.0	0.0	0.0	0.0
PL3	LOP: alarm delay		0	0	0	0	0	0
	0 = Function is inactive							
SH	Superheat value		-	-	-	-	-	-
PPU	valve ON rate		-	-	-	-	-	-
tGS	Superheat temperature sensor reading value		-	-	-	-	-	-
tEu	Superheat pressure sensor temperature value (value of the pressure equivalent to the temperature)		-	-	-	-	-	-
/cE	Saturated evaporation temperature calibration		0.0	0.0	0.0	0.0	0.0	0.0
Po6	PWM expansion valve T on/OFF period		6	6	6	6	6	6
cP1	Valve position when the control is ON		30	30	30	30	30	30
Pdd	Post-Defrost valve position		10	10	10	10	10	10
PSb	valve standby position		0	0	0	0	0	0
PF	valve opening stages		-	-	-	-	-	-

CAREL PARAMETERS		ISLAND FREEZER	WALL FREEZER	COMBI FREEZER	UPRIGHT FREEZER	COUNTER	MULTIDECK CABINET	
PMP	Electronic expansion valve manual operation activation	0	0	0	0	0	0	
	0 = inactive 1 = active							
PMu	Manual valve position	-	-	-	-	-	-	
Phc	Large capacity valve activation	0	0	0	0	0	0	
Cnf (Configuration)								
In	MPXPRO Unit type	1	1	1	1	1	1	
	0 = Slave 1 = Master							
Sn	Number of slave in local network	0	0	0	0	0	0	
	0 = No Slave							
H0	Supervisor and Master-Slave network address	199	199	199	199	199	199	
H1	AUX1 output configuration	8	8	8	8	8	8	
	0 = no function							7 = second Evaporator defrost output
	1 = alarm without energy normally							8 = Evaporator Fan output
	2 = energy alarm normally							9 = Glass heater output
	3 = auxiliary output							10 = Suction valve
	4 = auxiliary output shared by Master with slaves							11 = Compensation valve
	5 = Light output							12 = Solenoid valve
6 = auxiliary output shared by Master with slaves								
H2	Button set and remote control deactivation	1	1	1	1	1	1	
	1 = Button set and remote control is active							
H3	Remote control activation code	0	0	0	0	0	0	
	0 =no remote control activation code							
H4	Buzzer activation	0	0	0	0	0	0	
	0 = active; 1 = inactive							
H5	Please see AUX2 output configuration H1 parameter	7	2	2	2	2	2	
H6	Terminal button set locking configuration	0	0	0	0	0	0	
H7	Please see AUX3 output configuration H1 parameter	5	5	5	5	5	5	
H8	Output association with time bands	0	0	0	0	0	0	
	0 = Light 1 = AUX							

CAREL PARAMETERS		ISLAND FREEZER	WALL FREEZER	COMBI FREEZER	UPRIGHT FREEZER	COUNTER	MULTIDECK CABINET
H9	Output association with AUX button	0	0	0	0	0	0
	0 = Light 1 = AUX						
H10	Compressor output configuration	0	0	0	0	0	0
	0 = Cooling 1 = heating						
H11	Fan output configuration	0	0	0	0	0	0
	0 = Cooling 1 = Heating						
H12	Light sensor threshold	25	25	25	25	25	25
H13	Please see AUX4 output configuration H1 parameter	12	12	12	12	12	12
Hdn	default set parameters number	0	0	0	0	0	0
Htc	External time card insertion	0	0	0	0	0	0
	0 = not inserted						
rHu	Manual glass heater activation rate (rHt period)	70	70	70	70	70	70
	0 = Function is inactive						
rHt	Manual glass heater activation period	5	5	5	5	5	5
	0 = Function is inactive						
rHo	Glass heater modulation offset	2.0	2.0	2.0	2.0	2.0	2.0
rHd	Glass heater modulation difference	0.0	0.0	0.0	0.0	0.0	0.0
rHL	PWM output load type for glass heater modulation	0	0	0	0	0	0
	0 = resistant 1 = inductive						
rHA	Factor A for calculated glass temperature	2	2	2	2	2	2
rHb	Factor B for calculated glass temperature	22	22	22	22	22	22
HSt (Alarm log)							
HSo to 9	0 dan 9'a alarmlar (sete basin)	-	-	-	-	-	-
---	0 dan 9'a alarm kodu	-	-	-	-	-	-
h_	0 dan 9'a alarm houri	0	0	0	0	0	0
n_	0 dan 9'a alarm minutesi	0	0	0	0	0	0
---	0 dan 9'a alarm süresi	0	0	0	0	0	0
HcP (HACCP alarms)							
Ht0	HACCP alarm	0	0	0	0	0	0
HAn	HA alarm type number	0	0	0	0	0	0

CAREL PARAMETERS		ISLAND FREEZER	WALL FREEZER	COMBI FREEZER	UPRIGHT FREEZER	COUNTER	MULTIDECK CABINET
HA to HA2	HA type active HACCP alarm number	-	-	-	-	-	-
y_	From 1 to 3 alarm-Year	0	0	0	0	0	0
M_	From 1 to 3 alarm - month	0	0	0	0	0	0
d_	From 1 to 3 alarm - which day of the month	0	0	0	0	0	0
h_	From 1 to 3 alarm - hour	0	0	0	0	0	0
n_	From 1 to 3 alarm - minute	0	0	0	0	0	0
...	From 1 to 3 alarm - Alarm time	0	0	0	0	0	0
HFn	HF alarm type number	0	0	0	0	0	0
HF to HF2	HF type active HACCP alarm number	-	-	-	-	-	-
y_	From 1 to 3 alarm - Year	0	0	0	0	0	0
M_	From 1 to 3 alarm -month	0	0	0	0	0	0
d_	From 1 to 3 alarm - which day of the month	0	0	0	0	0	0
h_	From 1 to 3 alarm - hour	0	0	0	0	0	0
n_	From 1 to 3 alarm - minute	0	0	0	0	0	0
_	From 1 to 3 alarm - Alarm time	0	0	0	0	0	0
Htd	HACCP alarm delay	0	0	0	0	0	0
	0 = alarm viewing deactivated						
rtc (Real Time Clock)							
td1 to 8	Defrost time from 1 to 8 (press Set)	-	-	-	-	-	-
d_	From 1 to 8 defrost day selection	0	0	0	0	0	0
	0 = no defrost						
	1 to 7 = days one by one from Monday to Sunday						
	8 = every day from Monday to Friday						
	9 = everyday from Monday to Saturday						
	10 = only Saturday Sunday						
11 = everyday							
h_	Defrost hour	0	0	0	0	0	0
n_	Defrost minute	0	0	0	0	0	0
P_	Power defrost selection	0	0	0	0	0	0
	0 = Normal defrost; 1 =Power defrost						
tS1 to 8	Time band starting from 1 to 8 (press Set)	-	-	-	-	-	-
d	Time band starting: day	0	0	0	0	0	0
h	Time band starting: hour	0	0	0	0	0	0
n	Time band starting: minute	0	0	0	0	0	0
tE1 to 8	Time band end from 1 to 8 (press Set)	-	-	-	-	-	-

DANFOSS PARAMETERS		ISLAND FREEZER	WALL FREEZER	COMBI FREEZER	UPRIGHT FREEZER	COUNTER	MULTIDECK CABINET
Normal operation							
---	Temperature (setpoint)	-26	-20	-20	-20	0	2
Thermostat							
r01	Differential	2	2	2	2	2	2
r02	Max. limitation of setpoint setting	-22	-18	-18	-18	-4	-4
r03	Min. limitation of setpoint setting	-29	-23	-23	-23	4	4
r04	Adjustment of temperature indication	0	0	0	0	0	0
r05	Temperature unit (°C/°F)	0	0	0	0	0	0
r09	Correction of the signal from S4	0	0	0	0	0	0
r10	Correction of the signal from S3	0	0	0	0	0	0
r12	Manual service, stop regulation, start regulation (-1, 0, 1)	1	1	1	1	1	1
r13	Displacement of reference during night operation	0	0	0	0	0	0
r14	Define thermostat function	1	1	1	1	1	1
	1=ON/OFF						
	2=Modulating						
r15	Definition and weighting, if applicable, of thermostat sensors - S4% (100%=S4, 0%=S3)	100	0	0	0	50	50
r16	Time between melt periods	0	0	0	0	0	0
r17	Duration of melt periods	0	0	0	0	0	0
r21	Temperature setting for thermostat band 2 . As differential use r01	-26	-20	-20	-22	0	0
r59	Correction of the signal from S6	0	0	0	0	0	0
r61	Definition and weighting, if applicable, of thermostat sensors when night cover is on. (100%=S4, 0%=S3)	100	0	0	0	50	50
r62	Heat function	2	2	2	2	2	2
	Neutral zone between refrigeration and heat function						
r63	Time delay at switch between refrigeration and heat function	0	0	0	0	0	0
Alarms							
A03	Delay for temperature alarm	15	15	15	15	20	20
A04	Delay for door alarm	0	0	0	0	0	0
A12	Delay for temperature alarm after defrost	60	60	60	60	60	60
A13	High alarm limit for thermostat 1	-18	-15	-15	-15	4	6
A14	Low alarm limit for thermostat 1	-30	-26	-26	-26	-6	-6
A20	High alarm limit for thermostat 2	-18	-15	-15	-15	4	6
A21	Low alarm limit for thermostat 2	-30	-26	-26	-26	-6	-6
A22	High alarm limit for sensor S6 at thermostat 1	8	8	8	8	8	8
A23	Low alarm limit for sensor S6 at thermostat 1	-30	-30	-30	-30	-30	-30
A24	High alarm limit for sensor S6 at thermostat 2	8	8	8	8	8	8
A25	Low alarm limit for sensor S6 at thermostat 2	-30	-30	-30	-30	-30	-30

DANFOSS PARAMETERS		ISLAND FREEZER	WALL FREEZER	COMBI FREEZER	UPRIGHT FREEZER	COUNTER	MULTIDECK CABINET
A26	S6 alarm time delay	240	240	240	240	240	240
	With setting = 240 the S6 alarm will be omitted						
A27	Alarm time delay or signal on the DI1 input	30	30	30	30	30	30
A28	Alarm time delay or signal on the DI2 input	30	30	30	30	30	30
A36	Signal for alarm thermostat. S4% (100%=S4, 0%=S3)	100	0	0	0	50	50
A52	Delay for S6 (product sensor alarm) after defrost	90	90	90	90	90	90
Compressor							
c01	Min. ON-time	0	0	0	0	0	0
c02	Min. OFF-time	0	0	0	0	0	0
c05	Time delay for cutin of comp.2	5	5	5	5	5	5
Defrost							
d01	Defrost method	1	1	1	1	1	1
	0=off						
	1= EL						
	2= gAs						
d02	Defrost stop temperature	10	10	12	12	10	10
d03	Interval between defrost starts	8	8	6	6	6	6
d04	Max. defrost duration	35	35	35	35	45	45
d05	Displacement of time on cutin of defrost at start-up	0	0	0	0	0	0
d06	Drip off time	2	2	2	2	3	3
d07	Delay for fan start after defrost	2	2	2	2	0	0
d08	Fan start temperature	-5	-5	-5	-5	-5	-5
d09	Fan cutin during defrost	1	1	0	0	1	1
	0: Stopped						
	1: Running						
	2: Running during pump down and defrost						
d10	Defrost sensor	3	1	1	1	1	1
	0 =Stop on time						
	1=S5						
	2=S4						
	3=Sx						
(Application 1-8 and 10: both S5 and S6. Application 9: S5 and S5B)							
d16	Pump down delay	0	0	0	0	0	0
d17	Drain delay (used at hot gas defrost only)	0	0	0	0	0	0
d18	Max. aggregate refrigeration time between two defrosts	0	0	0	0	0	0
d20	Heat in drip tray. Time from defrosting stops to heating in the drip tray is switched off	30	30	30	30	30	30

DANFOSS PARAMETERS		ISLAND FREEZER	WALL FREEZER	COMBI FREEZER	UPRIGHT FREEZER	COUNTER	MULTIDECK CABINET	
t45	Clock - Setting of date	REAL TIME	REAL TIME	REAL TIME	REAL TIME	REAL TIME	REAL TIME	
t46	Clock - Setting of month	REAL TIME	REAL TIME	REAL TIME	REAL TIME	REAL TIME	REAL TIME	
t47	Clock - Setting of year	REAL TIME	REAL TIME	REAL TIME	REAL TIME	REAL TIME	REAL TIME	
Miscellaneous								
o01	Delay of output signals after start-up	5	5	5	5	5	5	
o02	Input signal on DI1. Function:	0	0	0	0	0	0	
	0=not used							7=thermostat band changeover (activate r21)
	1=status on DI1							8=alarm function when closed
	2=door function with alarm when open							9=alarm function when open
	3=door alarm when open							10=Appliance cleaning (pulse signal)
	4=defrost start (pulse-signal)							11=forced cooling at hot gas defrost
	5=ext.main switch							12=night cover
6=night operation	15=case shut down							
o03	Network address	0	0	0	0	0	0	
o04	On/Off switch (Service Pin message) IMPORTANT! o61 must be set prior to o04 (used at LON 485 and DANBUSS only)	Off	Off	Off	Off	Off	Off	
o05	Access code 1 (all settings)	0	0	0	0	0	0	
o06	Used sensor type	0	0	0	0	0	0	
	0=Pt1000 1=Ptc1000,							
o08	Readout of software version	**	**	**	**	**	**	
o16	Max hold time after coordinated defrost	20	20	20	20	20	20	
o17	Select signal for display view. S4% (100%=S4, 0%=S3)	100	0	0	0	50	50	
o20	Pressure transmitter working range – min. value	-1	-1	-1	-1	-1	-1	
o21	Pressure transmitter working range – max. value	12	12	12	12	12	12	

DANFOSS PARAMETERS			ISLAND FREEZER	WALL FREEZER	COMBI FREEZER	UPRIGHT FREEZER	COUNTER	MULTIDECK CABINET	
o30	Refrigerant setting:		19	19	19	19	19	19	
	1=R12	15=R227							29=R1270
	2=R22	16=R401A							30=R417A
	3=R134a	17=R507							31=R422A
	4=R502	18=R402A							32=R413A
	5=R717	19=R404A							33=R422D
	6=R13	20=R407C							34=R427A
	7=R13b1	21=R407A							35=R438A
	8=R23	22=R407							36=R513A
	9=R500	23=R410A							37=R407F
	10=R503	24=R170							38=R1234ze
	11=R11	25=R290							39=R1234yf
	12=R142b	26=R600							40=R448A
	13=User defined	27=R600a							41=R449A
14=R32	28=R744	42=R452A							
o30	Refrigerant setting:		19	19	19	19	19	19	
o37	Input signal on DI2. Function:		0	0	0	0	0	0	
	(0=not used.	5=ext. main switch							10=Appliance cleaning (pulse signal).
	1=status on DI2.	6=night operation							11=forced cooling at hot gas defrost.).
	2=door function with alarm when open.	7=thermostat band changeover (activate r21).							12=night cover,
	3=door alarm when open.	8=alarm function when closed.							13=coordinated defrost).
4=defrost start (pulse-signal).	9=alarm function when open.	15=case shut down							
o38	Configuration of light function:		1	1	1	1	1	1	
	1=Light follows day /night operation,								
	2=Light control via data communication via 'o39',								
	3=Light control with a DI-input,								
4=As "2", but light switch on and night cover will open if the network cut out for more than 15 minutes.									
o39	Activation of light relay (only if o38=2) On=light		Off	Off	Off	Off	Off	Off	
o41	Rail heat On time during day operations		100	100	100	100	100	100	
o42	Rail heat On time during night operations		100	100	100	100	100	100	
o43	Rail heat period time (On time + Off time)		10	10	10	10	10	10	
o46	Appliance cleaning.		0	0	0	0	0	0	
	0=no Appliance cleaning.								
	1=Fans only.								
2=All output Off.									
o61	Selection of EL diagram. See overview page 12 and 13		9	1	4	4	1	1	
o62	Download a set of predetermined settings. See overview page 27.		0	0	0	0	0	0	

DANFOSS PARAMETERS			ISLAND FREEZER	WALL FREEZER	COMBI FREEZER	UPRIGHT FREEZER	COUNTER	MULTIDECK CABINET	
o64	Access code 2 (partial access)		0	0	0	0	0	0	
o67	Replace the controllers factory settings with the present settings		Off	Off	Off	Off	Off	Off	
o84	Input signal on DI3. Function: (high voltage input)		0	0	0	0	0	0	
	(0=not used.	6=night operation,							12=night cover.
	1=status on DI2.	7=thermostat band changeover (activate r21)							13=Not used.
	2=door function with alarm when open.	8=Not used.							14=Refrigeration stopped (forced closing)).
	3=door alarm when open	9=Not used.							15=case shut down
	4=defrost start (pulse-signal).	10=Appliance cleaning (pulse signal).							
	5=ext. main switch	11=forced cooling at hot gas defrost,							
o85	Rail heat control		0	0	0	0	0	0	
	0=not used,								
	1=pulse control with timer function (o41 and o42),								
	2=pulse control with dew point function								
o86	Dew point value where the rail heat is minimum		8	8	8	8	8	8	
o87	Dew point value where the rail heat is 100% on		17	17	17	17	17	17	
o88	Lowest permitted rail heat effect in %		30	30	30	30	30	30	
o89	Time delay from "open door" refrigeration is started		30	30	30	30	30	30	
o90	Fan operation at stopped cooling (forced closing): 0= Stopped (defrost allowed)		1	1	1	1	1	1	
	1= Running (defrost allowed)								
	2= Stopped (defrost not allowed)								
	3= Running (defrost not allowed)								
o92	1=defrost stop temperature,		1	1	1	1	1	1	
	2=S6 temperature,								
	3=S5_B temperature (application 9), 4=S3B (application 10)								
o97	Display of temperature		1	1	1	1	1	1	
	1= u56 Air temperature								
	2= u36 product temperature								
o98	Light and night blinds defined		0	0	0	0	0	0	
	0: Light is switch off and night blind is open when the main switch is off								
	1: Light and night blind is independent of main switch								

DANFOSS PARAMETERS		ISLAND FREEZER	WALL FREEZER	COMBI FREEZER	UPRIGHT FREEZER	COUNTER	MULTIDECK CABINET
P41	Configuration of alarm relay	1	1	1	1	1	1
	The alarm relay will be activated upon an alarm signal from the following groups:						
	1 - High temperature alarms						
	2 - Low temperature alarms						
	4 - Sensor error						
	8 - Digital input enabled for alarm 16 - Defrosting alarms						
	32 - Miscellaneous 64 - Injection alarms						
The groups that are to activate the alarm relay must be set by using a numerical value which is the sum of the groups that must be activated. (E.g.: a value of 5 will activate all high temperature alarms and all sensor error and 0 will cancel the relay function).							